

Wireless | Independent Columns | 25 Seconds | **CE**
 Easy and Convenient | No Steel Ropes | Full rise

QUICKMULTI



E25



E25
Type M Arms (Optional)



E25

INDEPENDENT TWO COLUMN LIFT

- Rated capacity 5000kg, suitable for most sedans, heavy-duty SUVs, pickup trucks and vans.
- Flexible installation width to accommodate various vehicle sizes and installation spaces , recommended range: 2800-3500mm.
- A maximum pick-up height of 2000mm, providing greater under-vehicle workspace.
- Wireless synchronized hydraulic control system , capable of correcting height variations during lifting cycles.
- 24V safe control available at both columns for convenient and efficient operation.
- Touchscreen display for system setup and real-time height monitoring.
- Dual power units (3.5kW x 2) for powerful capability, only 25 seconds from bottom to top under rated load.
- Aluminium Shell Motor: Rapid dissipation, consistent efficiency.
- Dual safety against hydraulic leakage through mechanical latch and anti- burst hydraulic valve.
- Smart latch sensors decide whether to lower directly or raise before descent.
- APS control allows direct descent (safety lock disengaged) for rapid positioning
- Low-position stop and audible alarm for the final travel . No rail guards on the lift arms.
- Automatic engaging and disengaging swing arm locking device. Engage when raised and disengage at the lowest position.
- Optional M-Arms provide extensive wheelbase compatibility.



Intelligent Control System



HMI Screen
(Optional Load Display)



Control Panel



Height Limit Switch and
Displacement Sensor



Four 3-Stage Arms

OVERALL DIMENSION

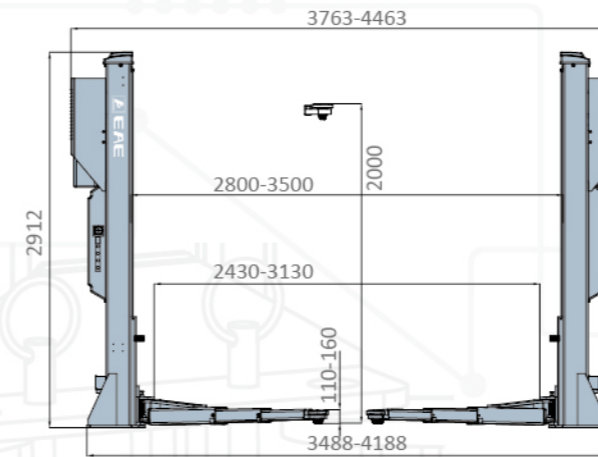

E25

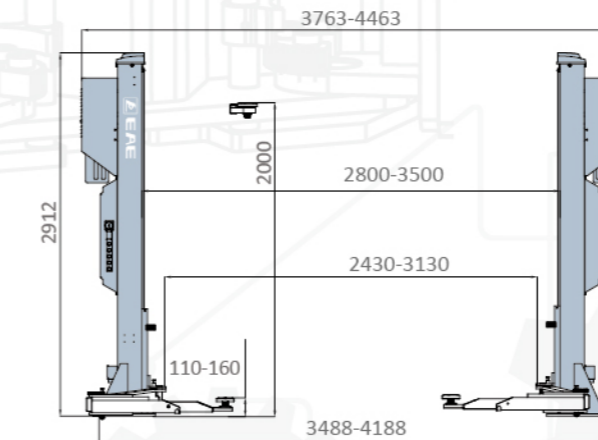
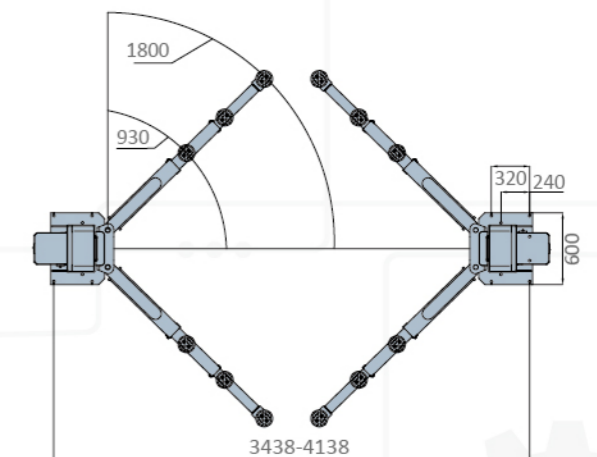

E25
Type M Arms

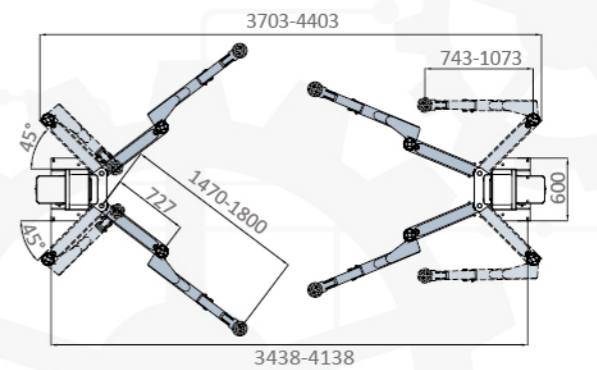

* The dimension schemes above illustrate the optimally designed column spacing. This spacing can be reduced based on available space constraints and vehicle models when necessary.

TECHNICAL DATA

MODEL NO.	E25
Lifting capacity	5.0T
Max lifting height	2000mm
Min height	110mm
Lifting time	Approx. 25S
Motor	3.5kWx2
Drive-through width (Adjustable)	2430-3130mm
Overall height	2912mm
Electricity supply	According To Customer Needs



* Max. Lifting height is measured with adjustable screw pads in highest position.
 * Machine shown with optional equipment. Actual product appearance may differ.