

Model No. EE-62CE-35T / EE-62CE-42T

Two Post Lift

Electrical Release

Asymmetrical/symmetrical Installation

Lifting Capacity 3500KG/4200KG

Installation, Operation And Parts Manual



EAE

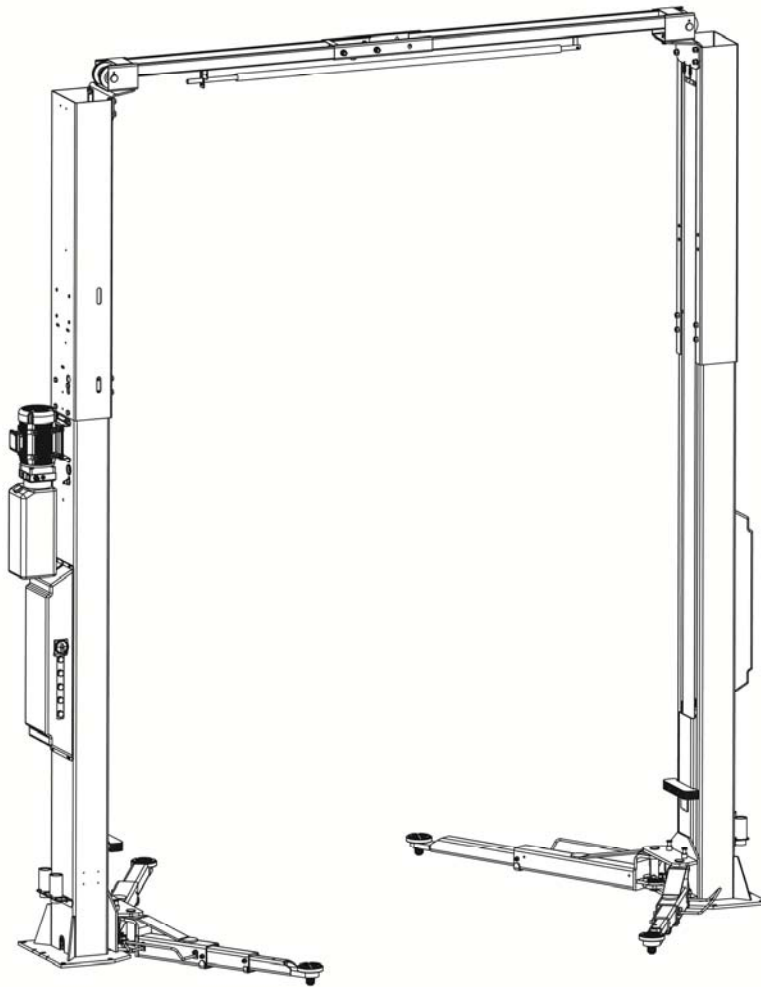

Distributed by

Please read this entire manual carefully and completely before installation or operation of the lift.

DATE: 10/06/2025

www.eae-ae.com

IMPORTANT NOTES

Before start up, connecting and operating products, it is absolutely essential that the operating instructions/owner's manual and, in particular the safety instructions are studied carefully. By doing so you can eliminate any uncertainties in handling products and thus associated safety risks up front; something which is in the interest of you own safety and will ultimately help avoid damage to the device, When a product is handed over to another person, not only the operating instructions but also the safety instructions and information on its designated use must be handed over to the person.

By using the product you agree the following conditions:

Copy right

The enclosed instructions are the property of the manufacturer or its supplier, and are protected against duplication and reproduction by copyright laws, international agreements, and other domestic legislation. The reproduction or disclosure of instructions or an extract thereof is prohibited and offenders are liable to prosecution; the manufacturer reserves the right or initiates criminal proceedings and asserts claims for damages in the event of infringements.

Warranty

The use of non-approved hardware will result in a modification of our products and thus to the exclusion of any liability or warranty, even if such hardware has been removed again in the interim.

It is not permissible to make any changes to our products and these are not only to be used together with genuine accessories and genuine replacement parts. Otherwise any warranty claims will be invalid.

Liability

The liability of the manufacturer is limit to the amount that the customer has actually paid for this product. This exclusion of liability does not apply to damages caused through willful misconduct or gross negligence on the part of the manufacturer.

All information in this manual is believed to be correct at time of publication.

The manufacturer reserves the right to amend and alter technical data and composition without prior notice.

Please confirm at time of ordering.

IMPORTANT NOTES	2
SAFETY NOTES	4
1.1 Operation of lifting platforms	4
1.2 Checking of the lifting platforms	4
1.3 Important safety notices	5
1.4 Warning labels	6
1.5 Potential safety risks	7
1.6 Noise level	7
PACKING, STORAGE AND TRANSPORTATION	7
2.1 The lift is delivered by 3 parts	7
2.2 Storage	7
2.3 Lifting and handling	8
PRODUCTS DESCRIPTIONS	9
3.1 General descriptions	9
3.2 Construction of the lift	10
3.3 Technical data	10
3.4 Dimensions	11
3.5 Safety devices descriptions	17
INSTALLATION INSTRUCTIONS	18
4.1 Preparations before installation	18
4.2 Installation attentions	19
4.3 General Installation Steps	19
4.4 Items to be checked after installation	34
OPERATION INSTRUCTIONS	35
5.1 Precautions	35
5.2 Operation instructions	35
TROUBLE SHOOTING	37
INSPECTION AND MAINTENANCE	39
Annex 1, Floor plan	42
Annex 2, Electrical diagrams and parts list	44
Annex 3, Hydraulic diagrams and parts list	48
Annex 4 , Mechanically exploded drawings and parts list	52

SAFETY NOTES

1.1 Operation of lifting platforms

This lift is designed for lifting normal on-road vehicles, such as passenger cars, buses and light trucks.

Users are not allowed to use it for any other purposes. The applicable national regulations, laws and directives must be observed.

Only users aged 18 or above who have been instructed on how to operate the lifting platform and have proven their ability to do so to the owner are to be entrusted with unsupervised operation of lifting platforms. The task of operating the lift must be granted in writing.

Before loading a vehicle onto the lift, users should study the original operation instructions and familiarize themselves with the operating procedures in several trial runs.

Lift vehicle within the rated load. Don't attempt to raise vehicles with excessive weight.

1.2 Checking of the lifting platforms

Checks are to be based on the following directives and regulations:

- Basic principles for testing lifting platforms
- The basic health and safety requirements stipulated in the directive 2006/42/EC
- Harmonized European standards
- The applicable accident prevention regulations

The checks are to be organized by the user of the lifting platform. The user is responsible for appointing an expert or qualified person to perform checking. It must be ensure that the person chosen satisfies the requirements.

The user bears special responsibility if employees of the company are appointed as experts or qualified persons.

1.2.1 Scope of checking

Regular checking essentially involves performing a visual inspection and a functional test. This includes checking the condition of the components and equipment, checking that the safety systems are complete and functioning properly and that the inspection log book is completely filled in. The scope of exceptional checking depends on the nature and extent of any structural modification or repair work.

1.2.2 Regular checking

After initial commissioning, lifting platforms are to be checked by a qualified person at intervals of not longer than one year.

A qualified person is somebody with the training and experience required to possess sufficient knowledge of lifting platforms and who is sufficiently familiar with the pertinent national regulations, accident prevention regulations and generally acknowledged rules of engineering to be able to assess the safe operating condition of lifting platforms.

1.2.3 Exceptional checking

Lifting platforms with a lift height of more than 2 meters and lifting platforms intended for use with people standing under the load bearing elements of the load are to be checked by an expert prior or reuse following structural modifications and major repairs to load bearing components.

An expert is somebody with the training and experience required to possess specialist knowledge of lifting platforms and who is sufficiently familiar with the pertinent national work safety regulations, accident prevention regulations and generally acknowledged

rules of engineering to be able to check and give an expert opinion on lifting platforms.

1.3 Important safety notices

1.3.1 The lift is designed for indoor installation only. Do not expose the lift to rain, snow or excessive moisture. Do not use the lift near explosives or open areas containing inflammable liquids.

1.3.2 Only use this lift on a surface that is stable and capable of sustaining the load. Do not install the lift on any asphalt surface.

1.3.3 Read and understand all safety warnings before operating the lift.

1.3.4 Do not leave the controls while the lift is still in motion.

1.3.5 Keep hands and feet away from any moving parts. Keep feet clear of the lift when lowering.

1.3.6 Only these properly trained personnel can operate the lift.

1.3.7 Do not wear unfit clothes such as large clothes with flounces, ties, etc., which could be caught by moving parts of the lift.

1.3.8 To prevent evitable incidents, surrounding areas of the lift must be tidy and with nothing unsecured.

1.3.9 The lift is simply designed to lift the entire body of vehicles, with its maximum weight within the lifting capacity.

1.3.10 Always insure the safety locks are engaged before any attempt to work near or under the vehicle. Never remove safety related components from the lift. Do not use if safety related components are damaged or missing.

1.3.11 Do not rock the vehicle while on the lift or remove any heavy component from vehicle that may cause excessive weight shift.

1.3.12 Check at any time the parts of the lift to ensure the agility of moving parts and the performance of synchronization. Ensure regular maintenance and if anything abnormal occurs, stop using the lift immediately and contact our dealers for help.

1.3.13 Lower the lift to its lowest position and do remember to cut off the power source when service finishes.

1.3.14 Do not modify any parts of the lift without manufacturer's advice.









1.3.15 If the lift is going to be left unused for a long time, users are required to:

- a. Disconnect the power;
- b. Empty the oil tank;
- c. Lubricate the moving parts with hydraulic oil.

WARNING: The warnings, cautions and instructions discussed in this instruction manual cannot cover all possible conditions and situations that may occur. It must be understood by the operator that common sense and caution are factors which cannot be built into this product, but must be supplied by the operator.

1.4 Warning labels

All safety warning labels are clearly depicted on the lift to ensure that the operator is aware of and avoid the dangers of using the lift in an incorrect manner. The labels must be kept clean and they have to be replaced if detached or damaged. Please read carefully the meaning of each label and remember them for future operation.

SAFETY ADVICE 540101581	
	<p>Only trained personnel are allowed to operate the lift.</p>
	<p>Always keep lift area clear when lowering or raising vehicle.</p>
	<p>Do not try to raise a vehicle exceeds the rated capacity.</p>
	<p>Always raise a vehicle with four swing arms.</p>
	<p>Position and adjust pads to lifting points recommended by vehicle manufacturers.</p>
	<p>Stop and check if arm locks and stability of vehicle after short raising, then to desired height.</p>
	<p>Watch closely the vehicle during raising or lowering.</p>
	<p>Always use safety stands when moving/installing heavy components.</p>
	<p>Avoid excessive rocking of vehicle while on lift.</p>
	<p>Do not climb onto the lift or raised vehicle during lifting or lowering.</p>
 www.eae-ae.com Copyright © EAE Automotive Equipment Company Limited. All rights reserved. 	

1.5 Potential safety risks

1.5.1 Main voltage



Insulation damage and other faults may result in accessible components being live.

Safety measures:

- Only ever use the power cord provided or a tested power cord.
- Replace wires with damaged insulation.
- Do not open the operating unit.

1.5.2 Risk of injury, danger of crushing

In the event of excessive vehicle weight, incorrect mounting of the vehicle or on removing heavy object, there is a risk of the vehicle falling off or tipping up.

Safety measures:

- The lift is only ever to be employed for the intended purpose.
- Carefully study and heed all the information given in section 1.4.
- Observe the warning notices for operation.

1.6 Noise level

Noise emitted during operating the lift should be less than 70dB (A). For your health consideration, it is suggested to place a noise detector in your working area.

PACKING, STORAGE AND TRANSPORTATION

Packing, lifting, handling, transporting operations must be performed only by experienced personnel with appropriate knowledge of the lift and after reading this manual.

2.1 The lift is delivered by 3 parts

Name	Packed by	Dimension(mm)	Weight (kg)	Quantity
Lift (35T)	Steel brackets	2860*570*770	625	1
Lift (42T)	Steel brackets	2860*570*770	655	1
Extending post	Bubble film	1300*400*250	66	1
Power unit	Carton	850*250*350	24	1

2.2 Storage

The packs must be kept in a covered and protected area in a temperature range of -10°C to +40°C. They must not be exposed to direct sunlight, rain or water.

Stacking the packs

We advise against stacking because the packs are not designed for this type of storage. The narrow base, heavy weight and large size of the packs make stacking difficult and potentially dangerous.

If stacking is unavoidable, use all appropriate precautions:

-Never stack to more than 2 meters in height.

-Never make stacks of single pack. Always stack pairs of packs in a cross pattern so that the base is bigger and the resulting stack is more stable. Once the stack is complete, restrain it using straps, ropes or other suitable methods.

A maximum of two packs can be stacked on lorries, in containers, and in railway wagons, on condition that the packs are strapped together and restrained to stop them falling.

2.3 Lifting and handling

The packs can be lifted and transported only by using lift trucks. Never attempt to hoist or transport the unit using lifting slings.

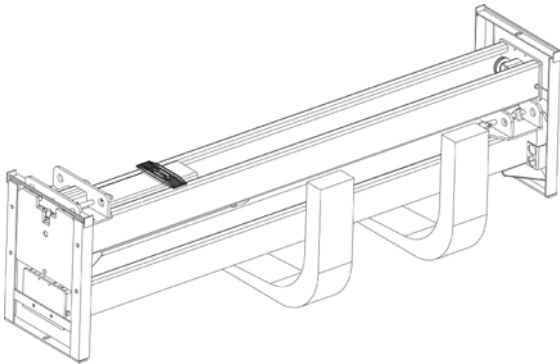

Opening the packs

When the lift is delivered make sure that it has not been damaged during transportation and that all the parts specified on the packing list are present.

Packs must be opened adopting all the precautions required to avoid injury to persons (keep at a safe distance when cutting the straps) or damage to parts of the machine (be careful that no parts are dropped while you are opening the packing)

Take special care with the hydraulic power unit, the control panel and the cylinder.

PRODUCTS DESCRIPTIONS

3.1 General descriptions

This is chassis supporting vehicle lift for road vehicles.

It is mainly composed by two posts, two carriages, four swing arms, a power unit and control unit.

It is driven by an electro-hydraulic system. The gear pump delivers hydraulic oil to oil cylinders and pushes upwards its piston. The cylinder piston drives to raise the carriage and swing arms. It is equipped with mechanical safety locking unit which ensures no risks of slipping off in case of hydraulic failure.

Depending on the ceiling height the work shop, the configuration can either be a total height of 3867mm or 4300mm.

Depending on the vehicles to be lifted, the column can either be installed symmetrically or asymmetrically.

The asymmetrical column configuration provides maximum door-opening clearance for passenger cars which have relative lower door position while the symmetrical column configuration provides more width between columns for vans and trucks which are wider and have relatively higher door position.

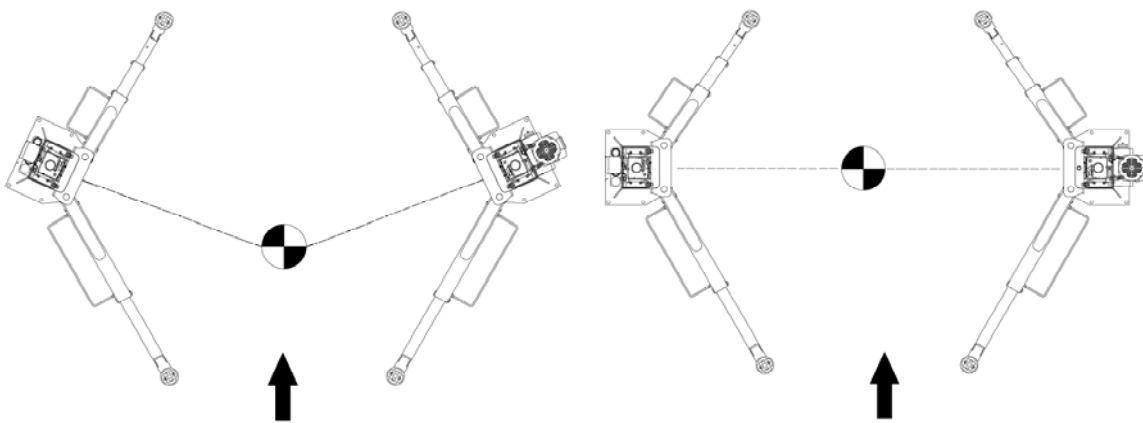

Vehicle center of gravity

3.2 Construction of the lift

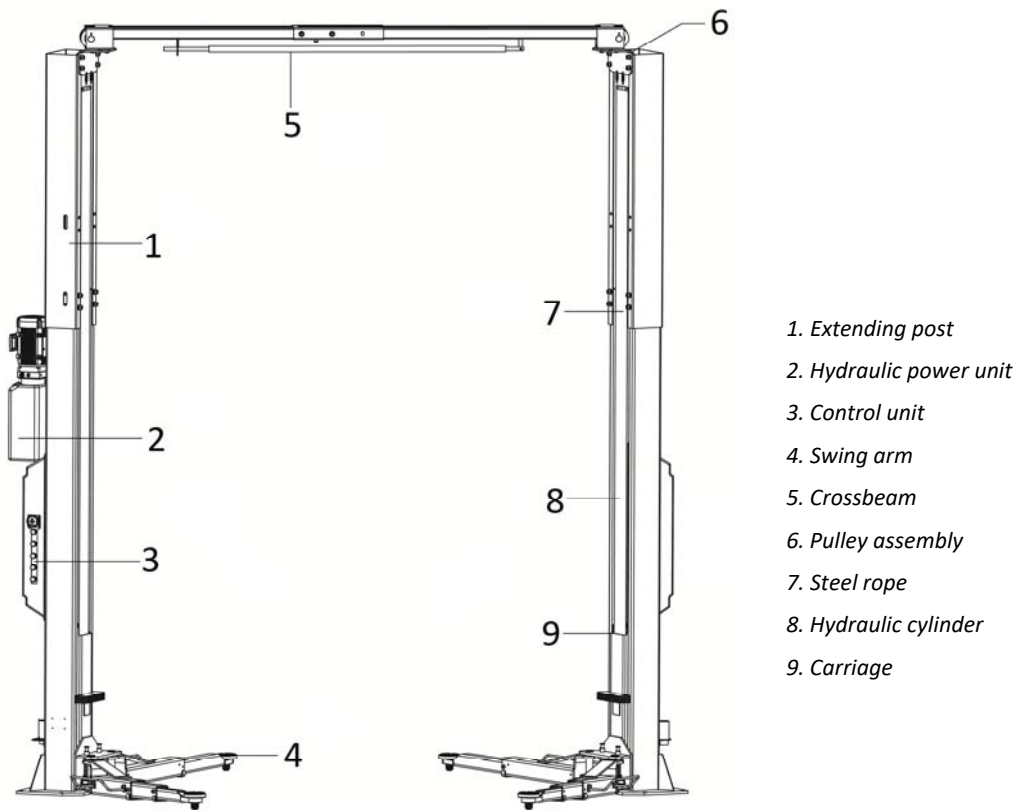

3.3 Technical data

Model	EE-62CE-35T	EE-62CE-42T
Lifting capacity	3500kg	4200kg
Full rise time (with rated load)	50s~65s (2.2kW 1Ph)	
	35s~40s (3.5kW 3Ph)	
Max height of the pick-up adapter	1900mm (locking device disengaged)	
Min height of the pick-up adapter	95mm (common arms/elbow arms)	
	85mm (low-profile arms)	
Applicable wheel track of the lift	≤2400mm	
Applicable wheel base of the lift	2000mm~3100mm	
Oil tank volume	10L	

3.4 Dimensions

3.4.1 Dimensions for asymmetrical column configuration

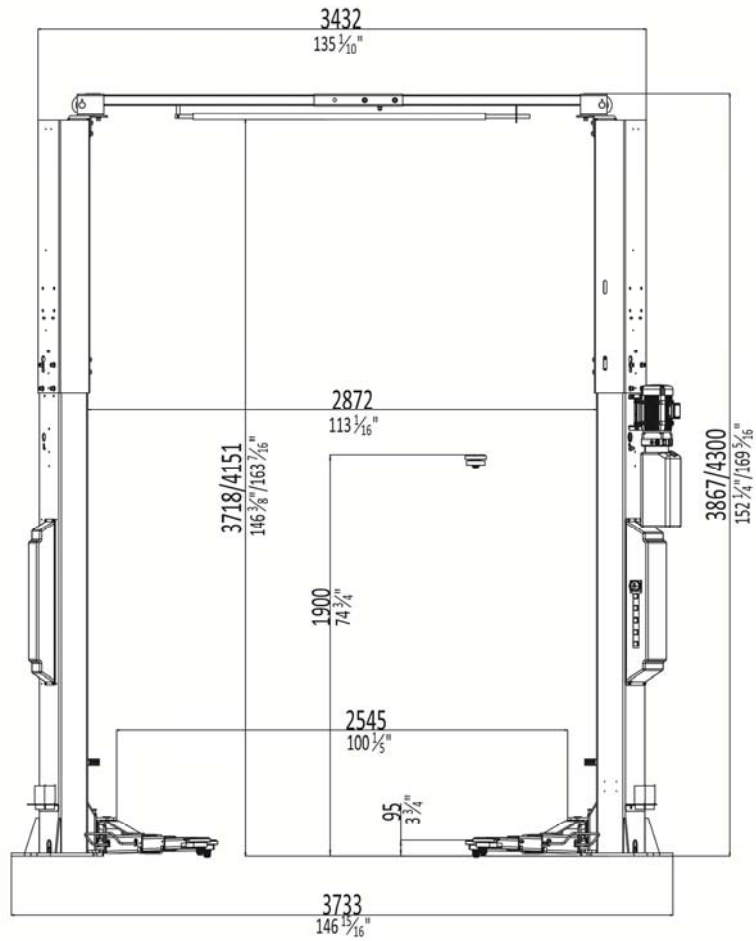

Two pieces of three-stage arm and two pieces of two-stage arm

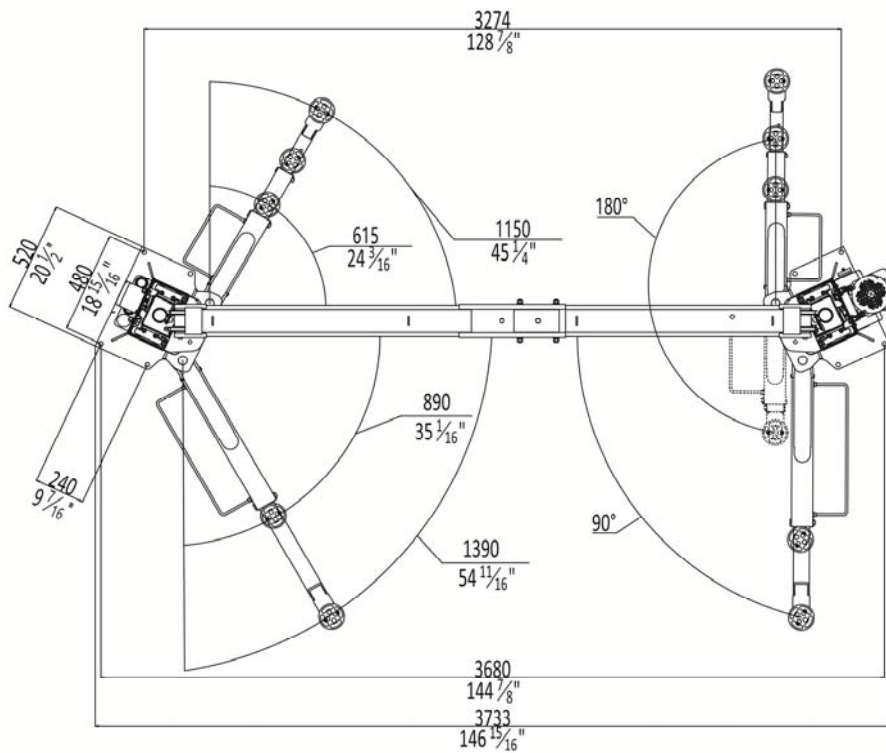

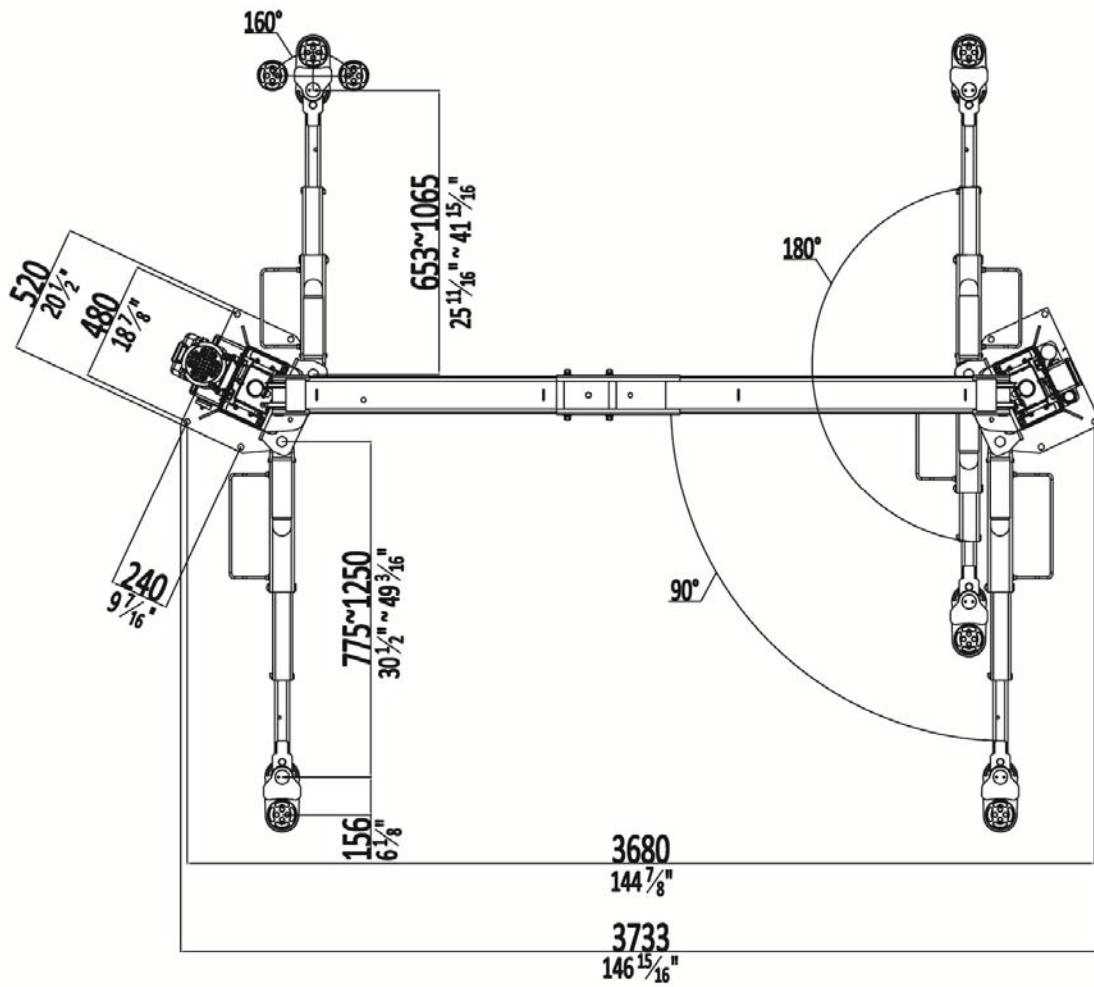
Optional elbow arm

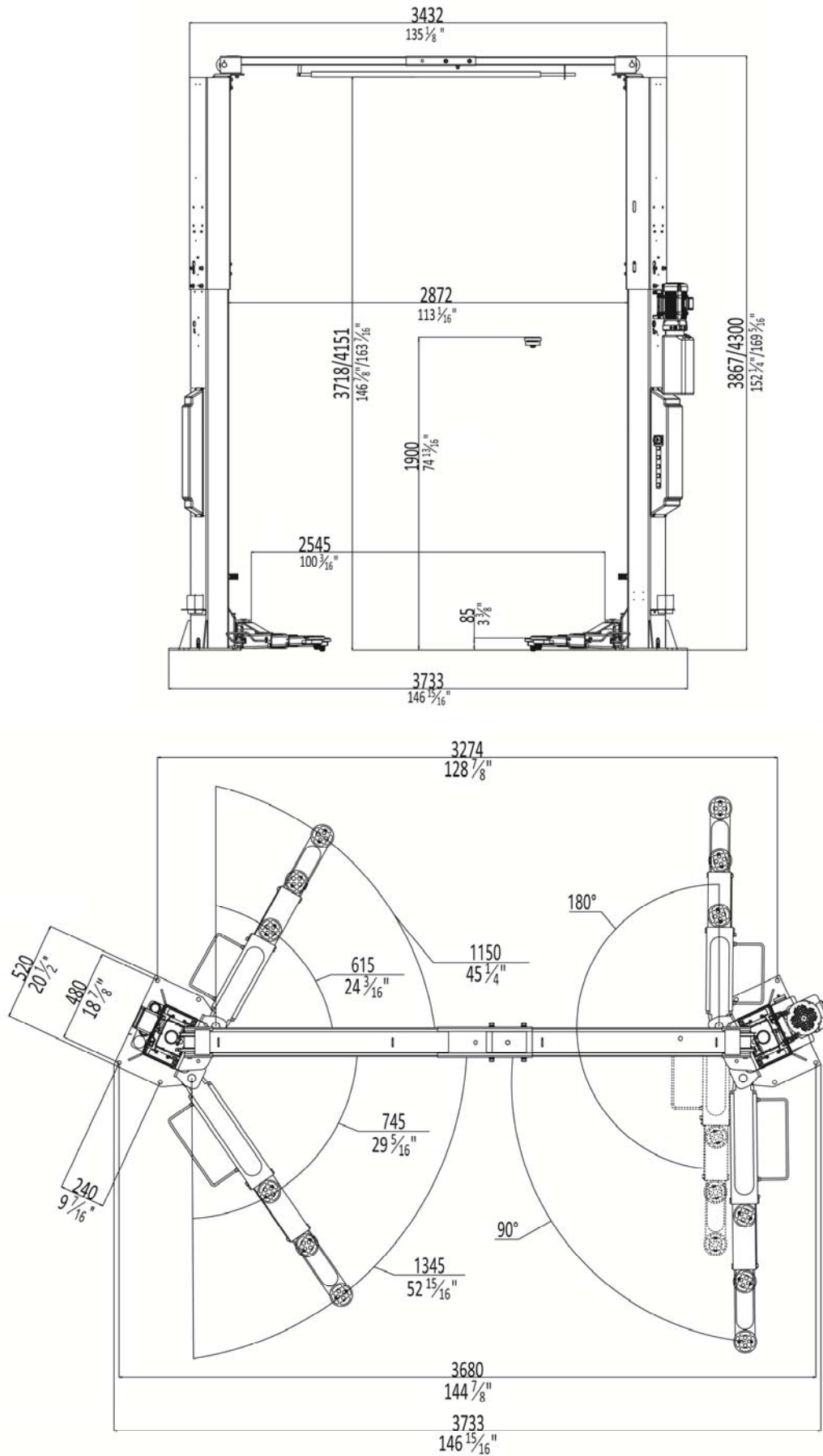
3.4.2 Dimensions for asymmetrical column configuration with optional low-profile arms

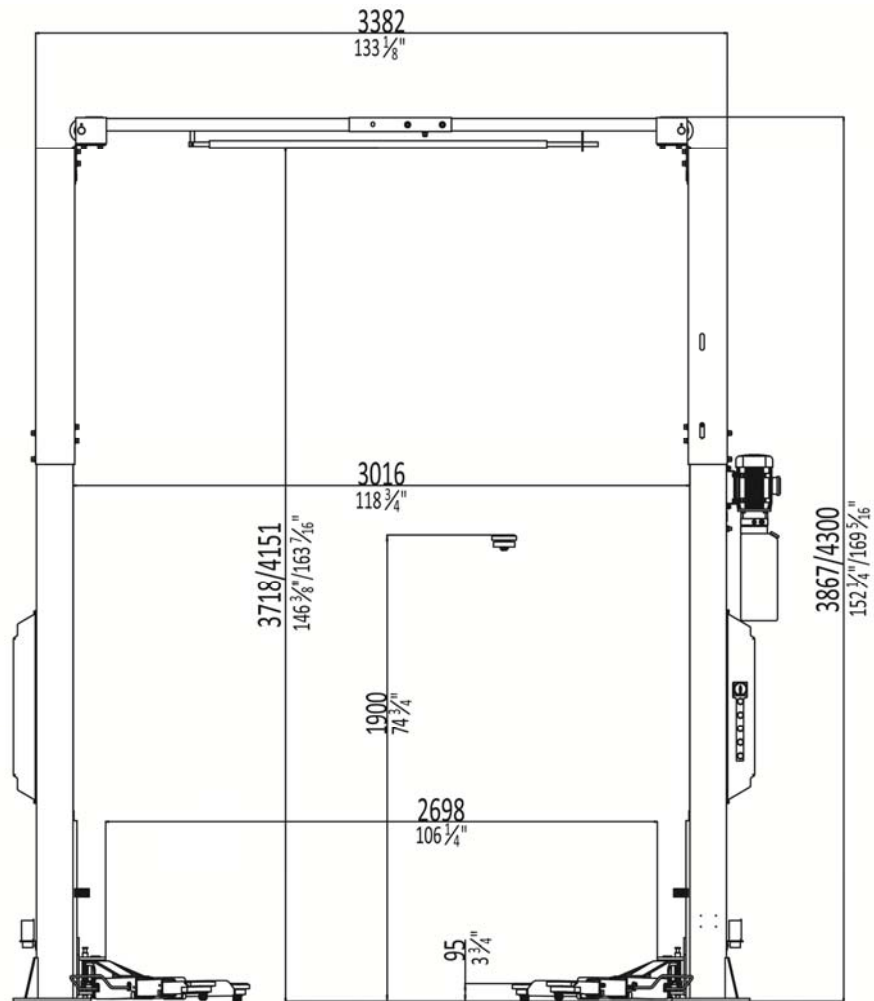
3.4.3 Dimensions for symmetrical column configuration

Two pieces of three-stage arm and two pieces of two-stage arm

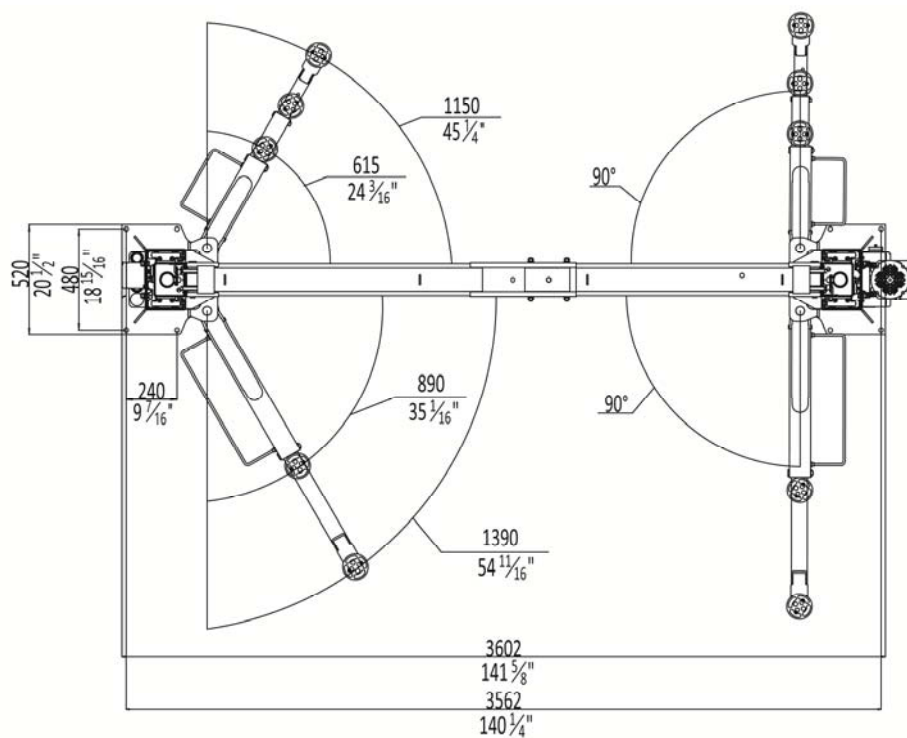

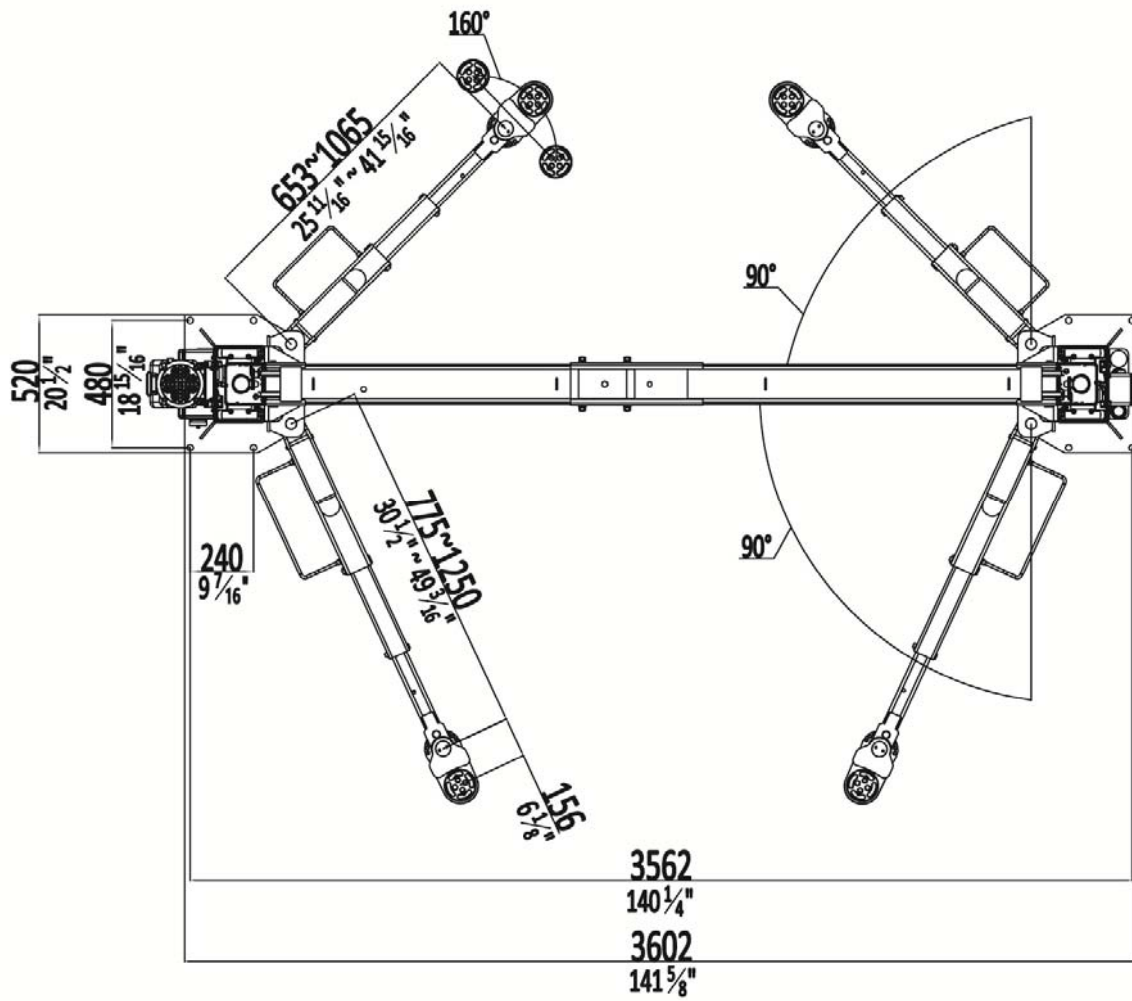
Optional elbow arm

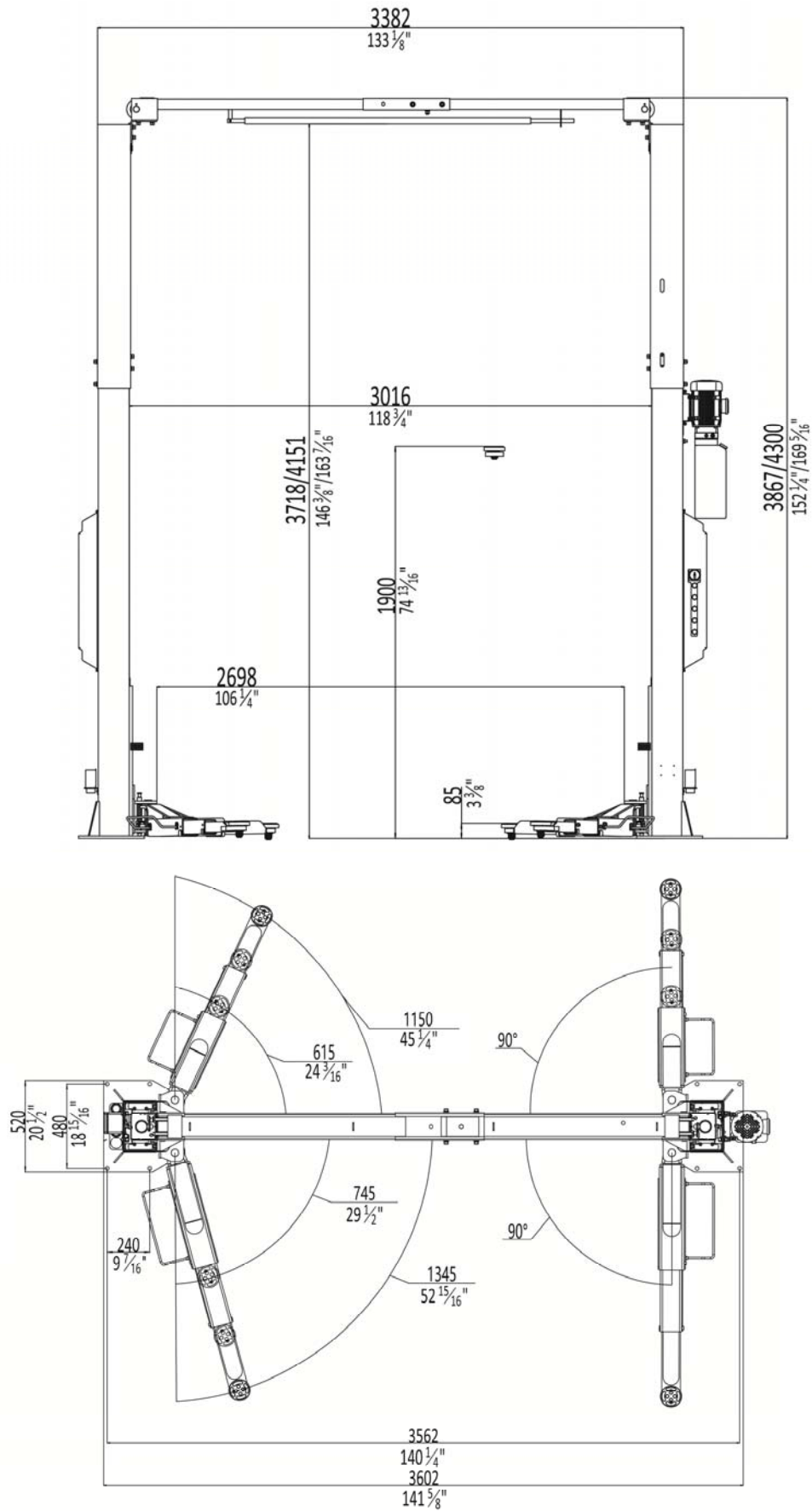
3.4.4 Dimensions for symmetrical column configuration with optional low-profile arms

3.5 Safety devices descriptions

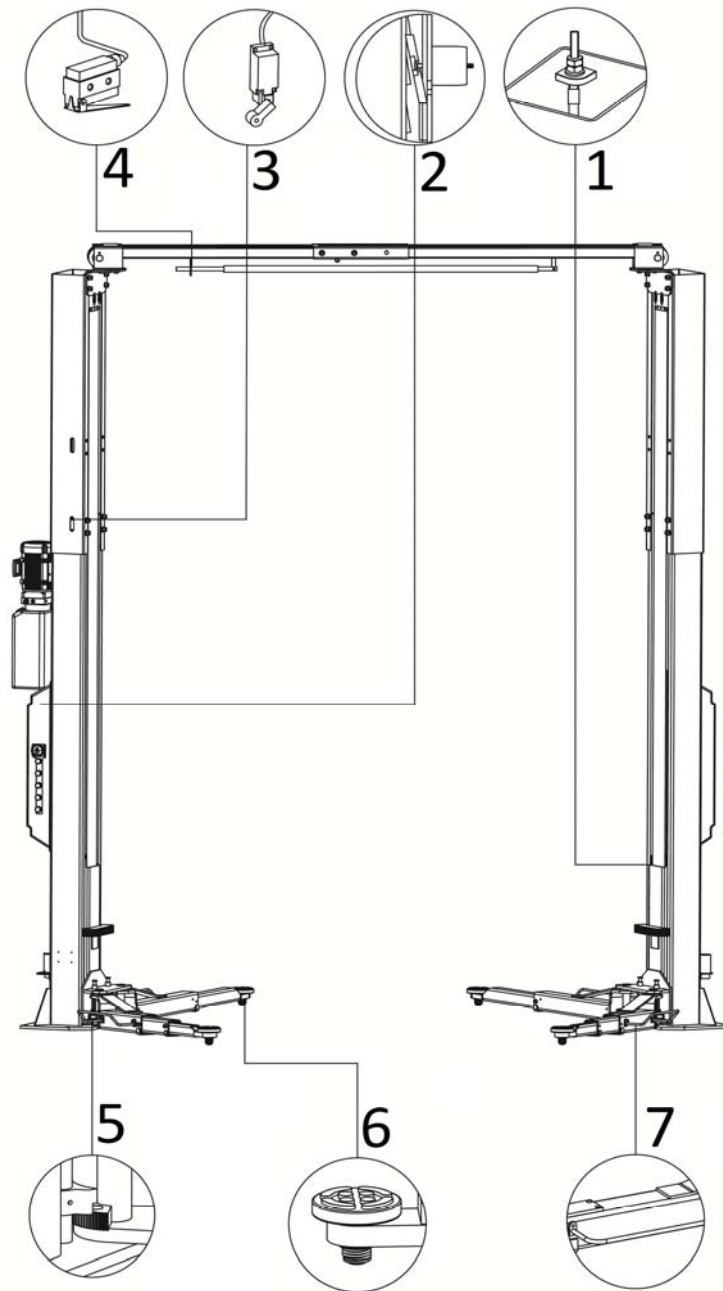

Pos.	Description	Function
1	Steel rope	Balance carriages at both sides.
2	Mechanical safety locking unit	Catch the carriages in case of hydraulic failure.
3	Max-height limit switch	Stop rising at maximum height.
4	Roof-protection limit switch	Stop rising in case the overhead bar is pushed upward by the roof of vehicle.
5	Arm lock	Lock the supporting arms and protect against swinging during lifting process.
6	Lifting pad	Safe rubber contact with the wheel base of lifted vehicle.
7	Fender	Protect feet from entering into danger areas that may cause pinching or shearing.

INSTALLATION INSTRUCTIONS

4.1 Preparations before installation

4.1.1 Space requirements.

The lift is designed for indoor installation only. Do not expose the lift to rain, snow or excessive moisture. Do not use the lift near explosives or open areas containing inflammable liquids.

Refer to 3.4 for the dimensions of the lift. There must be sufficient space for driving and lifting vehicles and enough safety distance shall be reserved according to the regulations of the local authorities. It is advised to reserve a clearance of at least 1 meter between the lift and fixed elements (e.g. wall) in all lifting positions.

4.1.2 Foundations and connections

The user must have the following work performed before erecting the lift.

- Construction of the foundation following consultation with the manufacturer's customer service or an authorized service agent. Routing of the wiring to the installation location. **The user must provide fuse protection for the connection. Electrical system connection must be done by a qualified electrician.** Requirements for power supply cord of the installation site: at least 2.5mm² wire core for 3Ph power and 4.0mm² wire core for 1Ph power.
- Refer also to the corresponding information on the name plate and in the operation instructions.
- Before doing electrical connection, make sure the lift is electrically adapt to the local power supply.

4.1.3 Foundations preparations

Refer to Annex 1 for footing.

C25/C30 concrete foundation with a minimum thickness of 200mm.

Surface under the base plates: Horizontal and even (Gradients max. 0.5 %).

Newly built concrete ground must be older than 20days.

4.1.4 Tools and equipment needed for installation

Tool name	Specification	Qty
Electrical drill	With D18 drill bit.	1
Open spanner	D17-19mm	2
Adjustable spanner	Bigger than D30mm	1
Cross socket screw driver	PH2	1
Quick spanner handle adapter/ Ratchet	REB-310	1
Levelling device	Accuracy: 1mm	1
Hammer	10 pounds	1
Truck lift	Capacity 1000kg	1
Torque spanner	MD400	1

4.2 Installation attentions

- 4.2.1 Tighten all hydraulic and electrical connections.
- 4.2.2 Tighten all screws, nuts and bolts.
- 4.2.3 Do not place any vehicle on the lift in the case of trial running.

4.3 General Installation Steps

ONLY TRAINED AND QUALIFIED INSTALLERS CAN PERFORM LIFT INSTALLATION DUTIES.



Step 1: Remove the packaging, take out the carton for accessories.

Attention : The packs must be opened adopting all the precautions required to avoid injury to persons (Keep at a safe distance when cutting the straps) or damage to parts of the machine (Be careful that no parts are dropped while you are opening the packing).

Step 2: Firstly, put something supporting between the two posts or suspend one of the posts by a crane and then remove the bolts from the packing frame.

Attention : Please pay special attention not to let the post fall down, otherwise there could be risks of getting hurt or damaging the accessories fixed in the post.

Step 3: When the first post has been taken away, place something supporter under the second post and then remove the bolts from the packing frame

Step 4: Connect extending piece for posts and assemble the crossbeam.
1. Assembly the extending piece.

There are four pairs of holes reserved on extending piece.

On condition that the ceiling of your workshop is higher than 4300mm, it is preferred to fix the extending piece with the main column using the pairs of holes P3 and P4.

If the ceiling is lower than 4300mm, you have to tighten the extending piece using the pairs of holes P1 and P2.

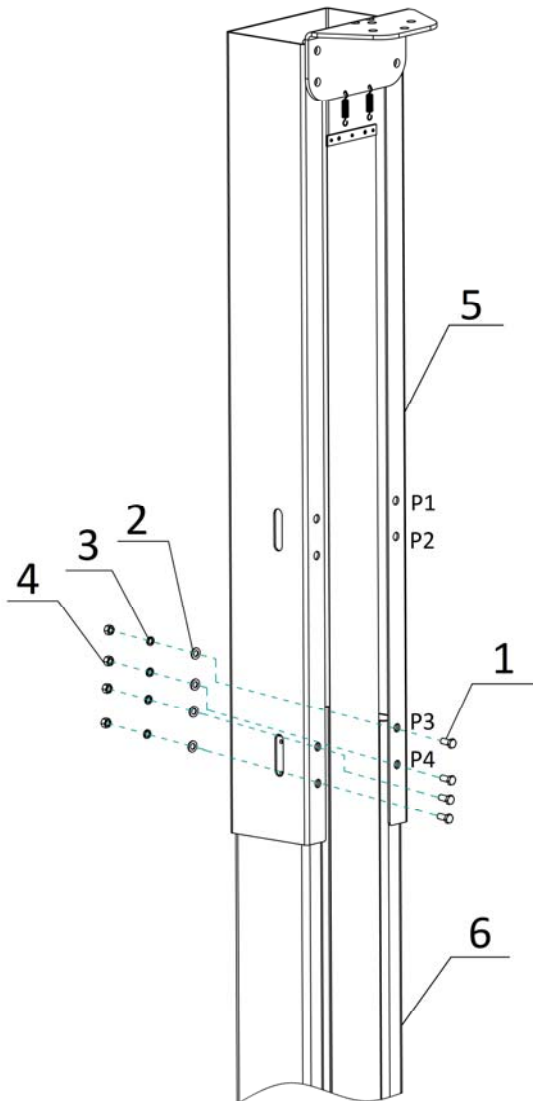

1. Hex head full swivel screw M14*30
2. Flat washer M14
3. Spring washer M14
4. Hex nut M14
5. Post 1
6. Post 2

2. Assembly the overhead crossbeams and fix the roof protective rod.

First, connect beam 1 and beam 2 using hex head full swivel screw M14*30. Then, fix the roof protective rod using hex socket cylinder head screw M6*35.

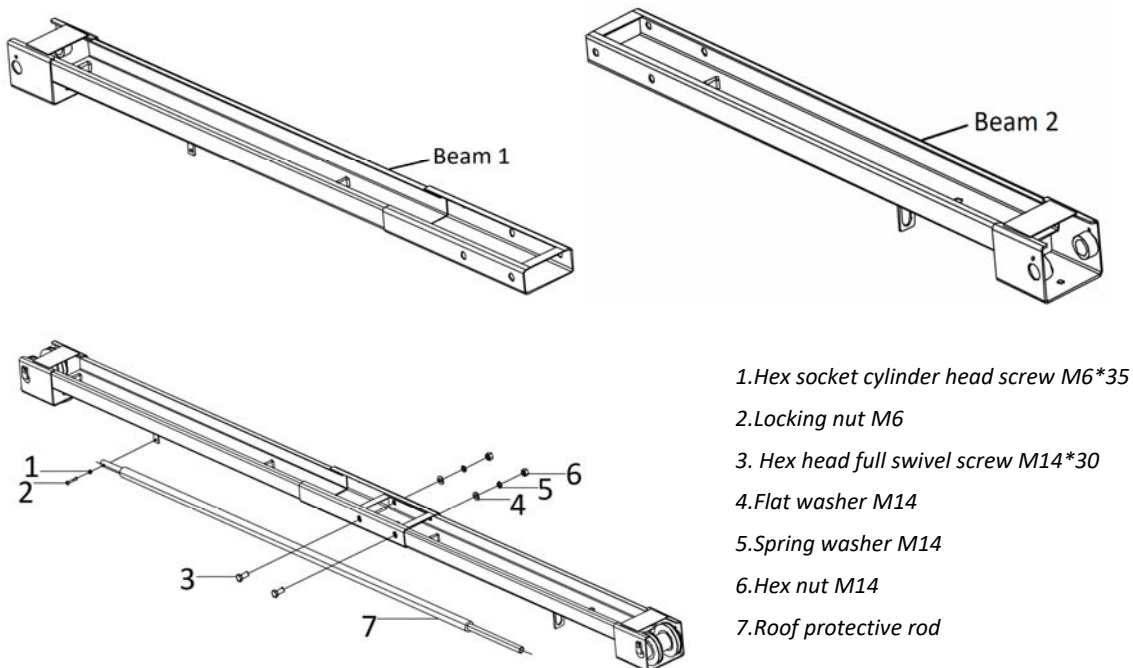

Step 5: Ascertain the mounting position and erect the posts. (See Annex 1, Floor plan)

1. Ascertain the type of configuration.

Depending on the ceiling height the work shop, the configuration can either be a total height of 3867mm or 4300mm.

Depending on the type of vehicles to be lifted, the column configuration can either be symmetrically or asymmetrically.

2. Identify on which post the power unit will be mounted.

3. Draw an outline of the base plate on the installation ground with chalk and ascertain the position for the two posts. (Refer to the fig. in step 6)

4. Refer to the 3.4 dimensions of the lift, make the posts face to each other and use proper means to erect the posts.

Step 6: Secure the post with the floor using anchoring bolts.

1. Check and align the position of the two base plates again.

Floor plan for asymmetrical column configuration

Align the two base plates, making the marking points C1, C2, C3 and C4 are in the same straight line.

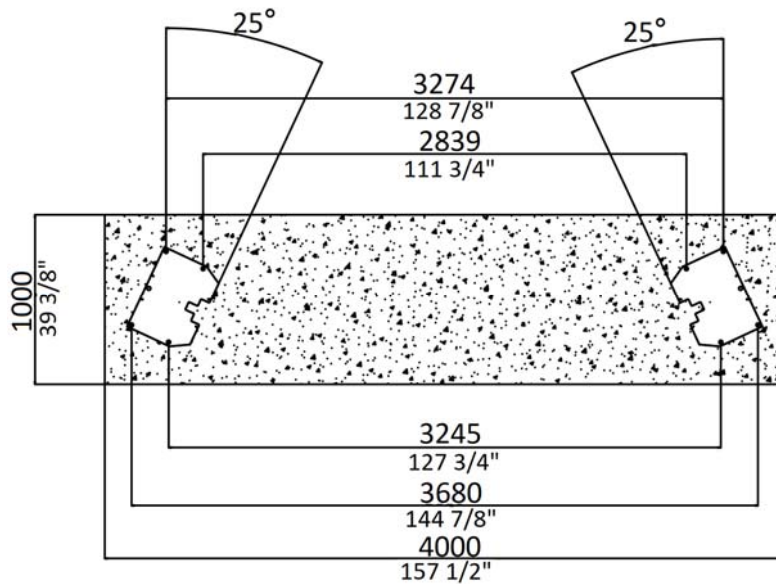
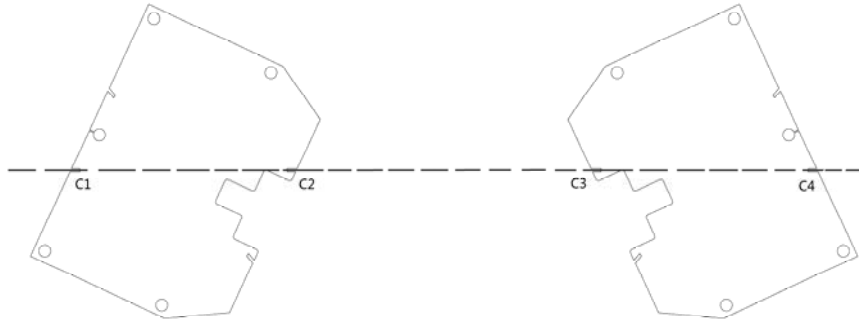
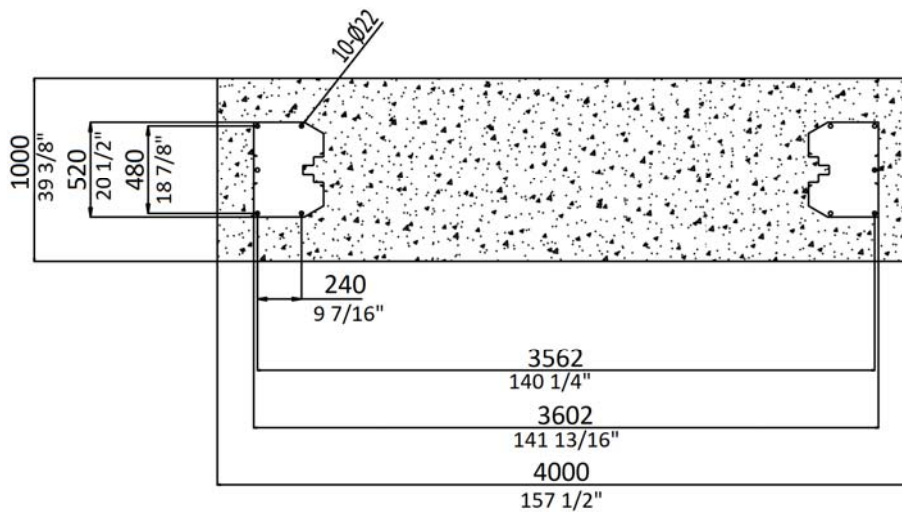
Floor plan for symmetrical column configuration

2. Use suitable means to raise the lifting carriage to the first latching position. All the mounting holes in the base plate are then accessible. Make sure the locking pawl is engaged.
3. Drill the mounting holes. Remove the drilling dust from the hole.
4. Use a spirit level to check the vertical alignment of the posts. Place equalizing plates under the base plates when it necessary to assure the verticality of the post.

Caution: Don't add more than 1 equalizing plate under one anchor position of the base plate, otherwise there could be risks of slanting due to uneven load transfer to the foundation.

5. Tighten the nuts. **Torque: 80-100Nm.**

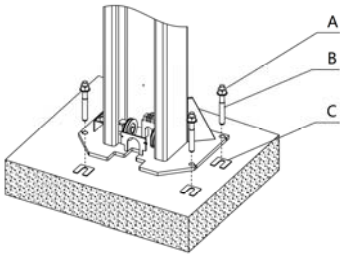

- A. Nut
- B. Expansion anchoring bolt
- C. Equalizing plate

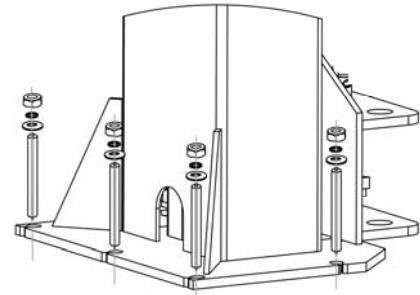
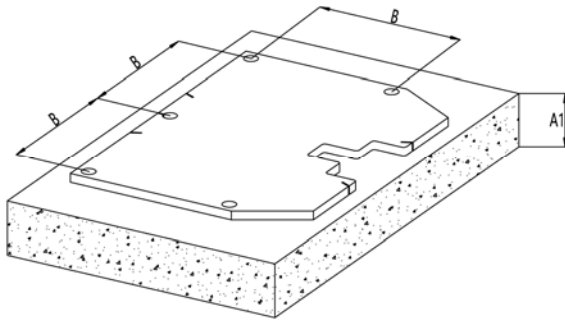

Anchoring bolt	A1 (Foundation thickness)	A2 (Drilling depth)	A3 (Anchoring depth)	B	C
M18x160	≥200mm	130mm	105mm	240mm	≤55mm

Step 7: Install the crossbeam onto the two posts.

Refer to the following Fig.1 and Fig.2 for two types of configuration, ascertain and mark the right holes on the connecting part (Pos.5).

Tighten the beam with the two connecting parts and connect the beam with the two posts by tightening the two connecting parts with the two posts.

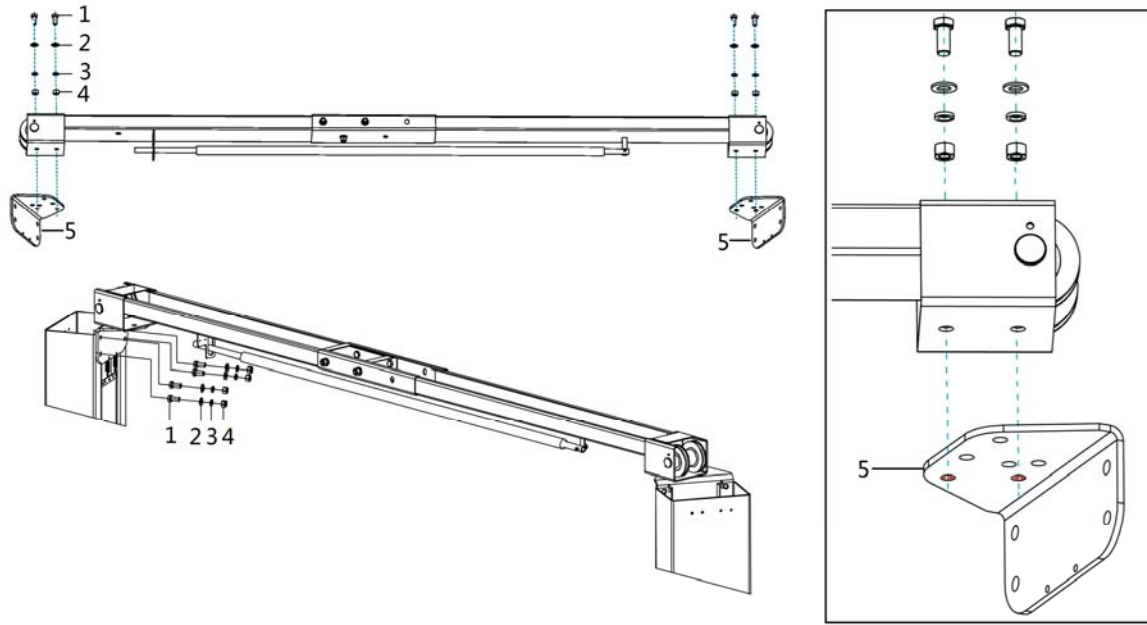
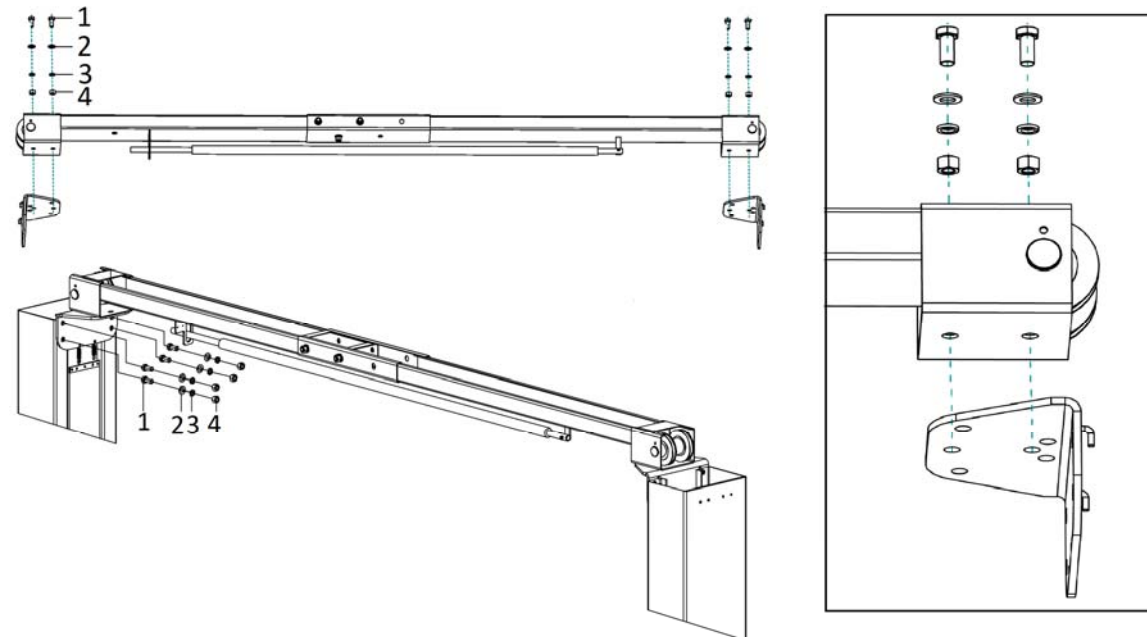
Fig.1 Correct connecting position for Asymmetrical column configuration.

Fig.2 Correct connecting position for Symmetrical column configuration.

- | | |
|--------------------------------------|--------------------|
| 1. Hex head full swivel screw M14*30 | 4. Hex nut M14 |
| 2. Flat washer M14 | 5. Connecting part |
| 3. Spring washer M14 | |

Step 8: Install the mechanical locking unit.

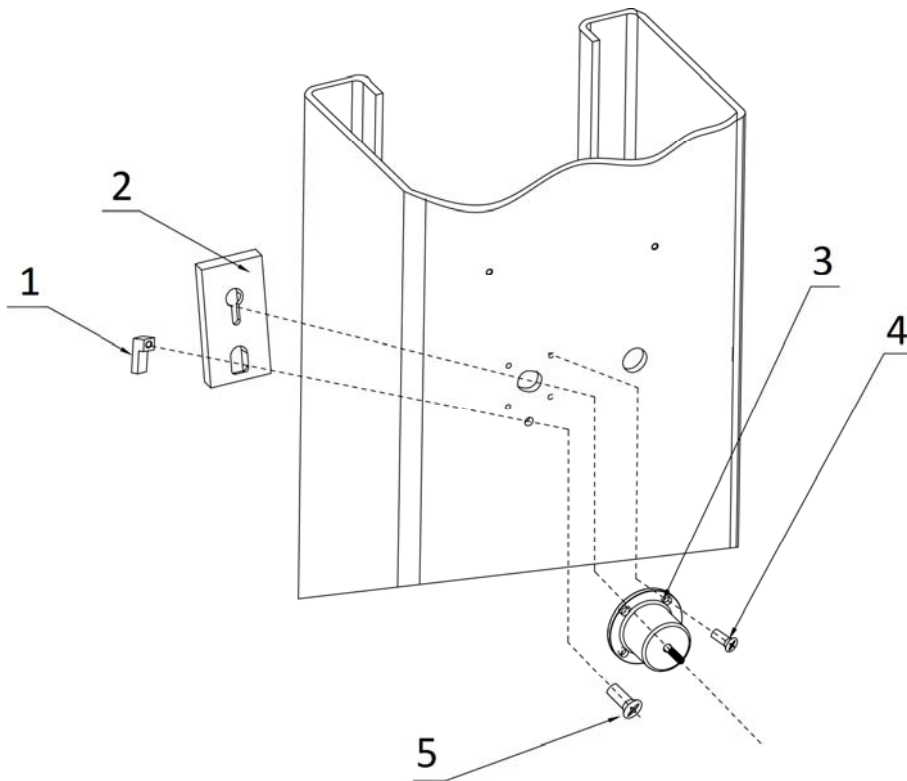
Fix four safety locking plates and electromagnets with two of them on each post.



- 1 *Orientation block*
- 2 *Safety locking plate*
- 3 *Electromagnet*
- 4 *Hex socket cylinder head screw M6*8*
- 5 *Hex socket cylinder head screw M6*15*

Step 9: Connect steel ropes.

1. Ascertain the height configuration.
2. Before attempting to route the ropes, raise the lifting carriage at both sides to the first latching position making sure that the mechanical safety locking units in each post are fully engaged.
3. The following scheme indicates rope tightening positions for configuration with a total height of 3867mm.
4. For higher configuration with a total height of 4300mm, tighten the two ends of ROPE 2 from P1 to P2 and from P3 to P4, tighten the two ends of ROPE 1 from P5 to P1 and from P4 to P6.

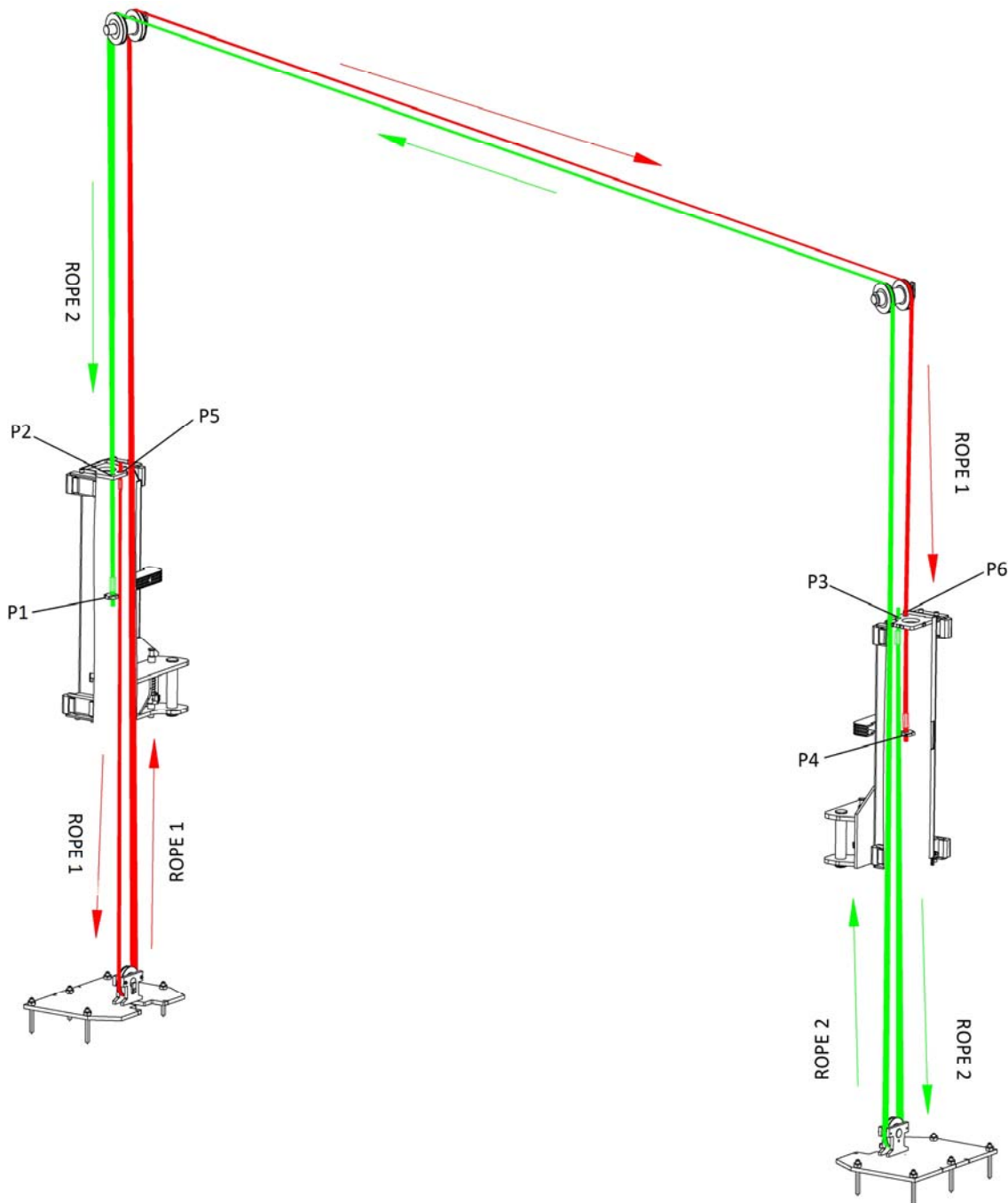

5. Adjust and make the ropes at both sides be under the same tension which could be judged by the sound emitted during lifting process.
6. Grease with No.1 lithium grease

Step 10: Install the power unit.

Mount the power unit onto the power side post.

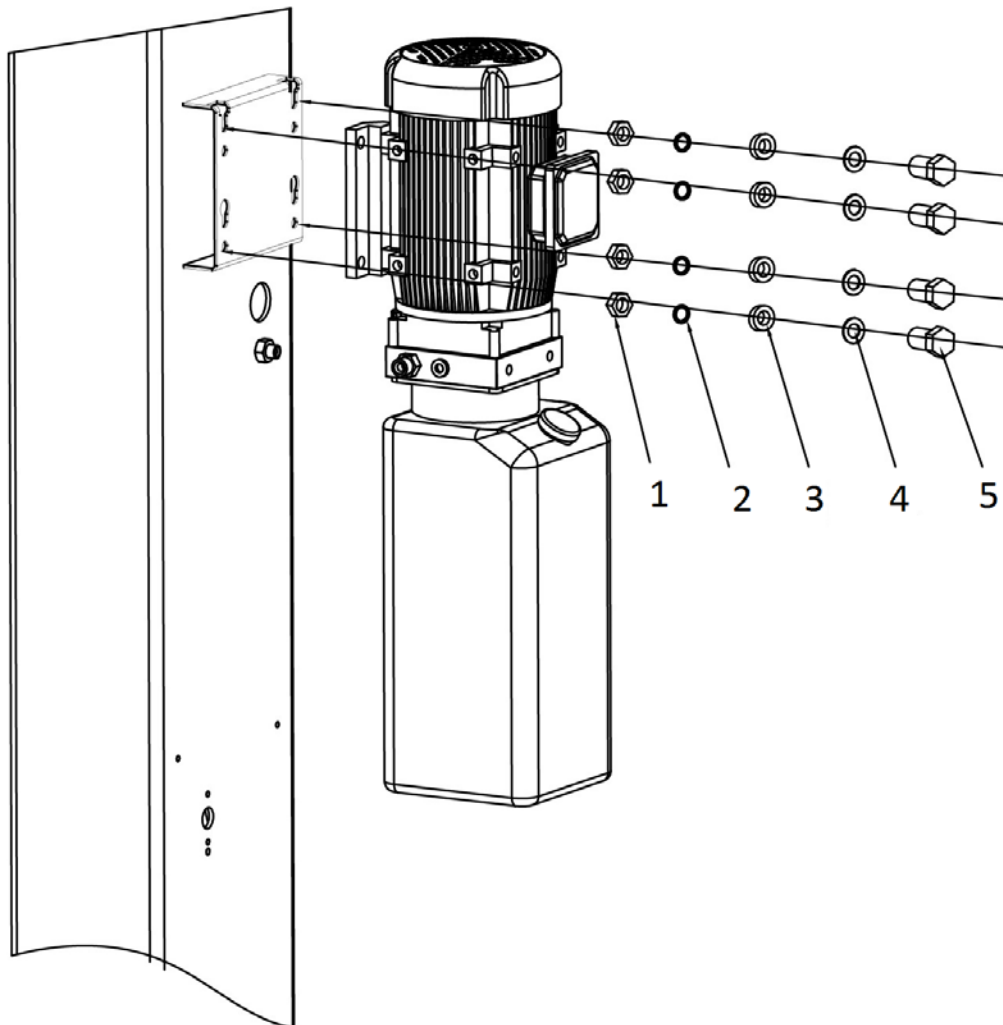

1.Hex nut M10

2.Spring washer M10

3.Flat washer M10

4.Anti-shock pad

5.Hex head full swivel screw M10x35

Step 11: Connect the hydraulic hoses.

The following diagram shows the way of connection for the total height configuration of 4300mm.

Connect hose 3 (Pos.6) directly with the three-way connector (Pos.3) for lower height configuration of 3867mm.

It must be taken adequate care that all connectors shall be tightened against leakage. Don't let any solid substance go into the hydraulic line. Severe leakage will occur if the hose connectors are not tightened.

Screw torque: 25-30Nm.

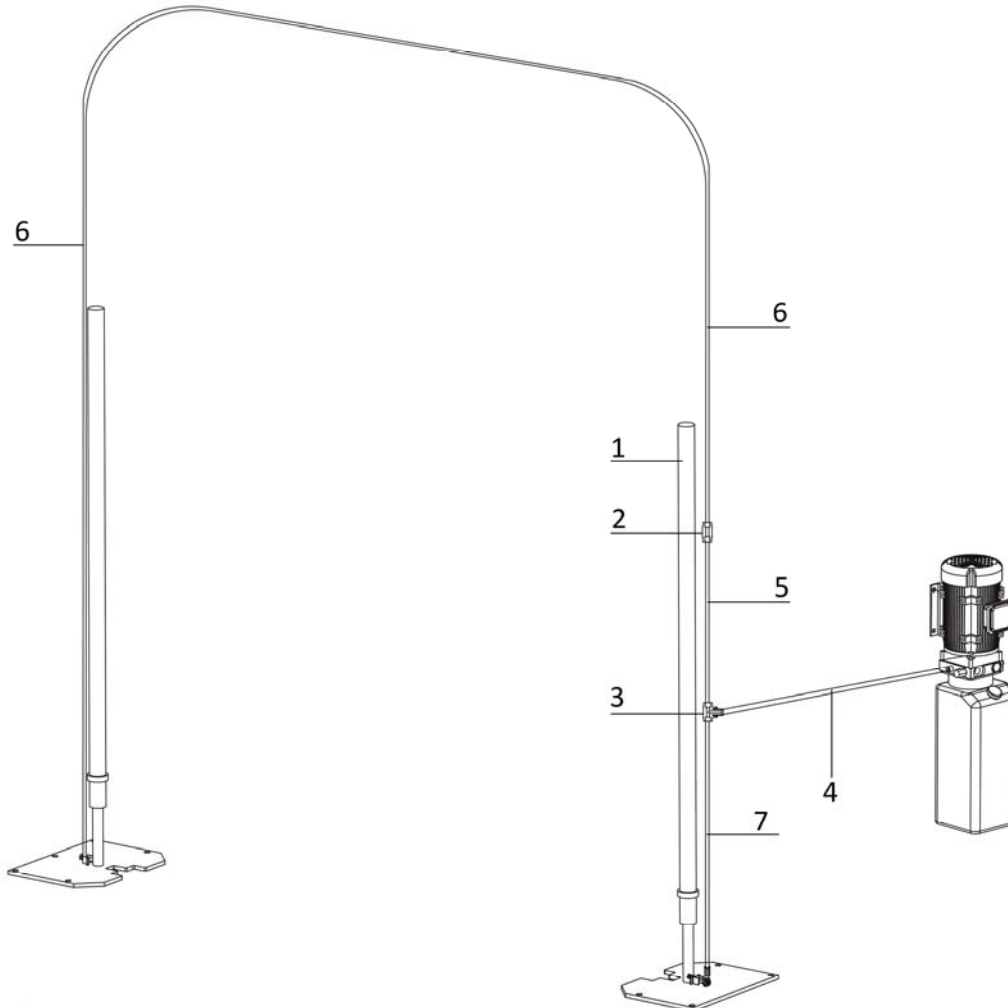

1. Oil cylinder
2. Straight connector (optional, only usable for a total height of 4300mm)
3. Three way connector
4. Rubber oil hose 1, L=320mm
5. Rubber oil hose 2, L=840mm (optional, only usable for a total height of 4300mm)
6. Rubber oil hose 3, L=8625mm
7. Rubber oil hose 4, L=2265mm

Step 12: Install the control unit.

ONLY qualified electricians are permitted to do the electrical connection.

Read the name plate and check that the supply voltage is adapted to the voltage of the lift.

Read electrical connection diagram in Annex 2 for reference before doing the connection.

Caution: All electrical wires shall be properly secured against interference with the wire ropes.

1. Mount the control box onto the power side post.

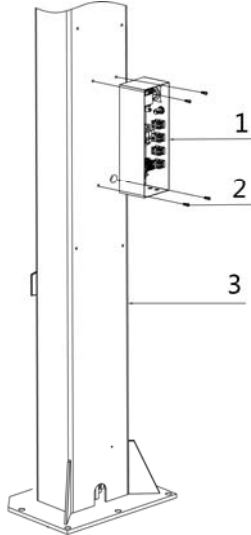

1. Control box

2. Hex socket cylinder head screw M6x10

3. Power side post

2. Fix the max-height limit switch onto the inside surface of the power side post.

Connect the wires of the switch with the corresponding terminals reserved in the control box.

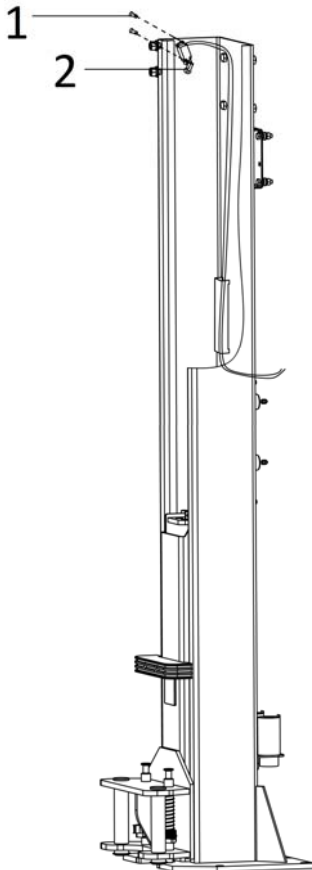

1. Cross socket flat head screw M5x10

2. Max-height limit switch

3. Fix roof-protection limit switch onto the overhead crossbeam and connect its wires with the corresponding terminals reserved in the control box.

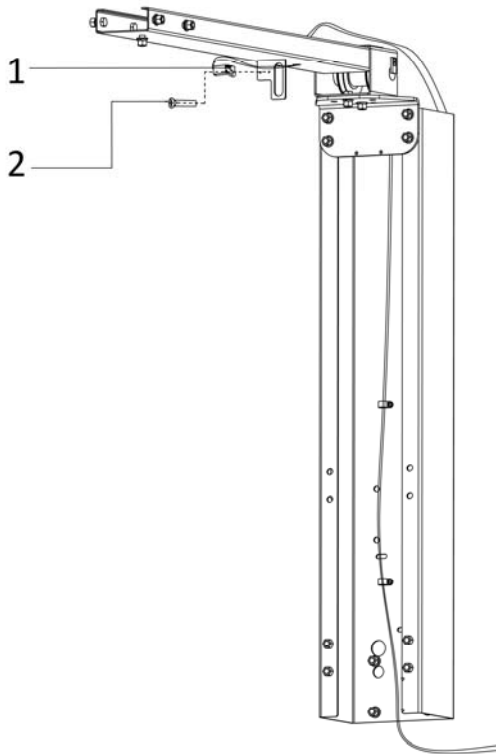

1. Roof protection limit switch

2. Cross socket flat head screw M4x25

4. Connect quick connectors between electromagnets.

Connect the wires to the corresponding terminals reserved in the control box.

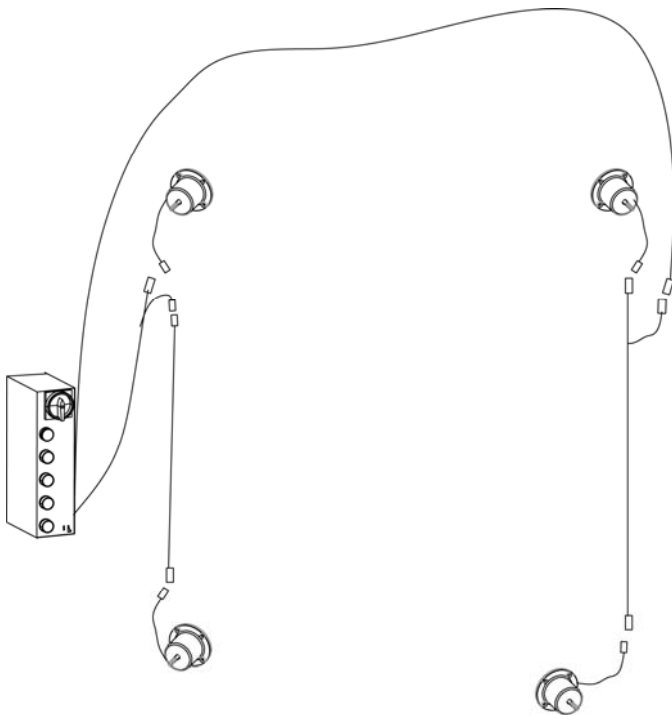

5. Connect the solenoid valve wire and motor wire.

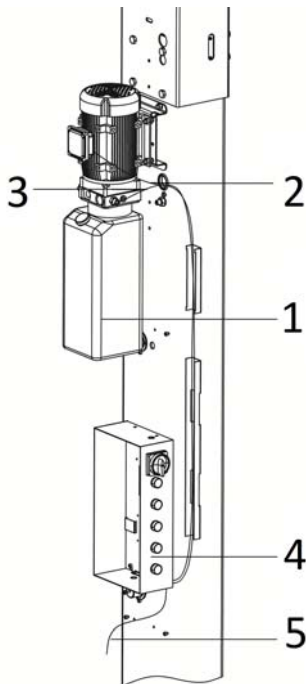

- 1. Power unit
- 2. Motor wire
- 3. Solenoid valve wire
- 4. Control box
- 5. Power supply wire

Step 13: Install swing arms.

Connect the four swing arms with the carriage using pin shafts. The pin shafts (No. 2) shall be greased at the installation.

Check and ensure the arm lock can engage and release effectively.

Caution: Install lifting arms and fix feet protection bars ONLY after the complete assembly has been erected and anchored.

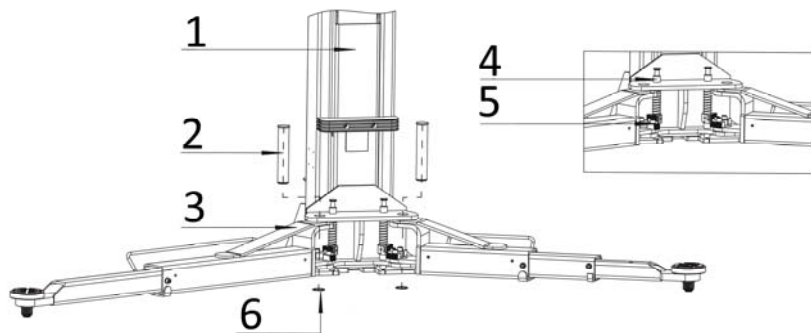

- 1. Carriage
- 2. Pin shaft
- 3. Swing arm
- 4. Pulling rod
- 5. Arm locking unit
- 6. Circlip D38

Step 14: Fill with hydraulic oil.

CLEAN AND FRESH OIL ONLY. DON'T FILL THE TANK COMPLETELY FULL.

Lift must be lowered till the bottom before changing or adding hydraulic oil

Prepare 10 liters of anti-abrasion hydraulic oil. The level of oil shall reach the tippets volume mark of the tank.

After bleeding the hydraulic system, add more oil after running the lift for several cycles until the lift can rise to the maximum lifting height.

It is suggested to use HM NO.46 hydraulic oil. When average temperature of the location is below 10°C, use HM NO.32 hydraulic oil.

Change the oil 6 months after initial use and change once per year thereafter.

Step 15: Trial commissioning.

The purpose for trial commissioning is to check whether the lift is ready to be raised and lowered smoothly for safe use.

The user shall get familiar with lift controls through raising and lowering the lift a few cycles before using it to lifting vehicles.

Bleeding the hydraulic system.

Vent air remained the oil cylinder. Screw loose the nut on top of the oil cylinder and slightly press the UP button until oil gets out. Screw the nut tight thereafter.



Vent air remained in the cylinder

After bleeding, fluid level in power unit reservoir may go down. Add more fluid if necessary to raise lift to full height. It is only necessary to add fluid to raise lift to full height.

Check the mechanical safety locking system.

Check if mechanical locks can be well engaged and released in the lifting and lowering process.

Check the synchronization of lifting carriages.

Adjust the nuts that fix the ropes at both sides, making them be under the same tension.

This could be judged by the sound emitted by the safety locking unit during lifting process.

Check the hydraulic lines.

Raise and lower for several complete cycles and inspect if the hose connectors, cylinders and valves are well tightened without leakage.

Check the speed for rising and lowering, ensuring that the maximum permitted speeds are not exceeded.

If the lift doesn't raise, the motor may turn in the wrong direction. In such event, interchange wires U, V in the connection box.

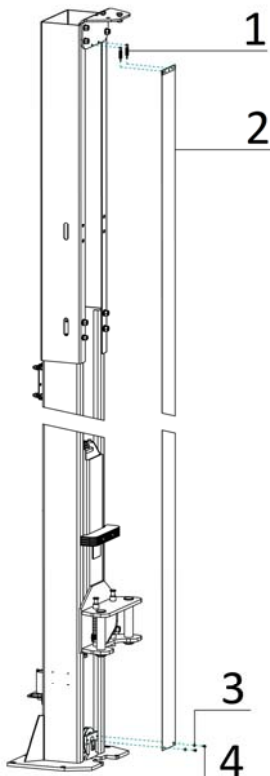
Step 16: Fix the curtain for each post.

1. Spring

2. Column curtain, L= 3440mm (usable for a total height of 3867mm)

2. Column curtain, L=3875mm (usable for a total height of 4300mm)

3. Flat washer M6

4. Cross socket cap head screw M6x8

Step 17: Fix two protective covers.

Fix the covers (Pos.2, Pos.4) onto the posts.

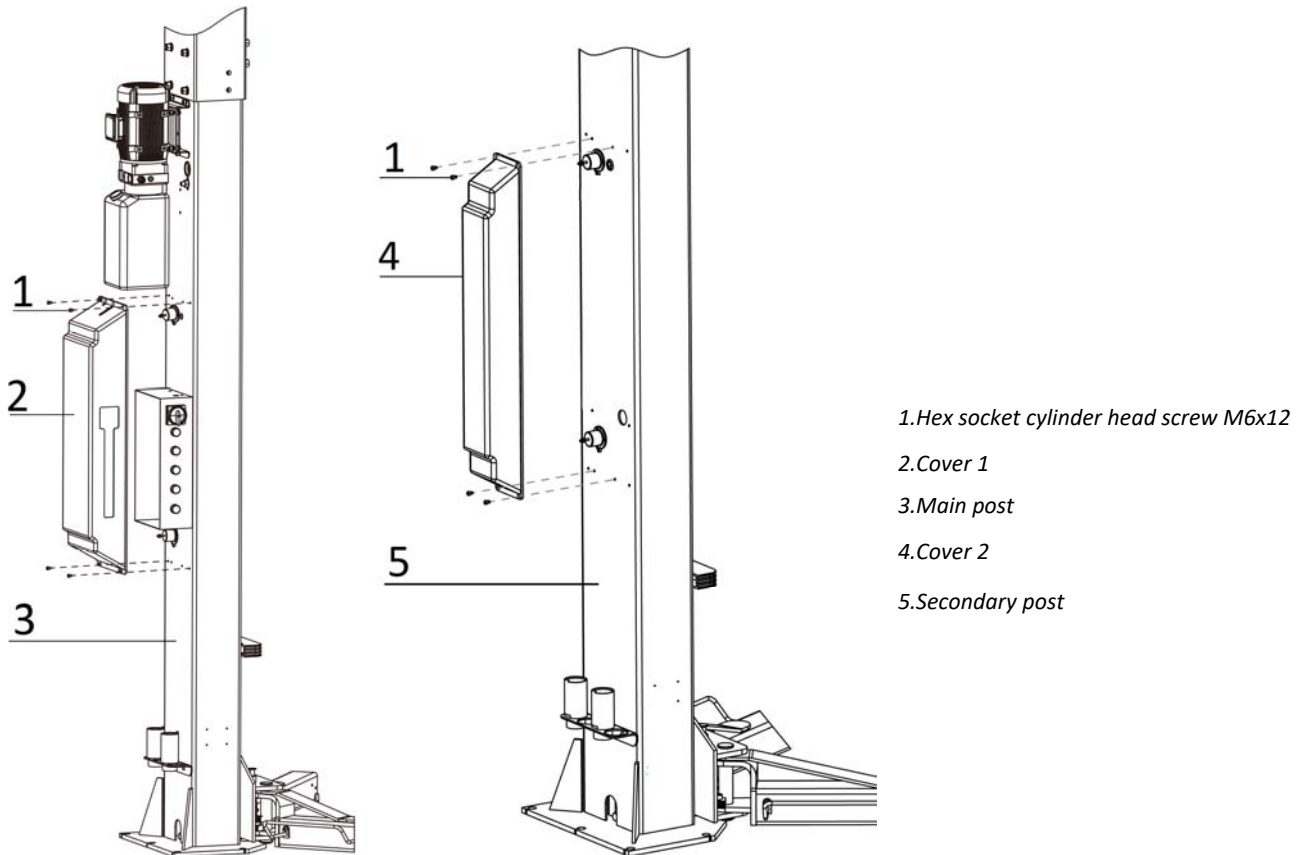
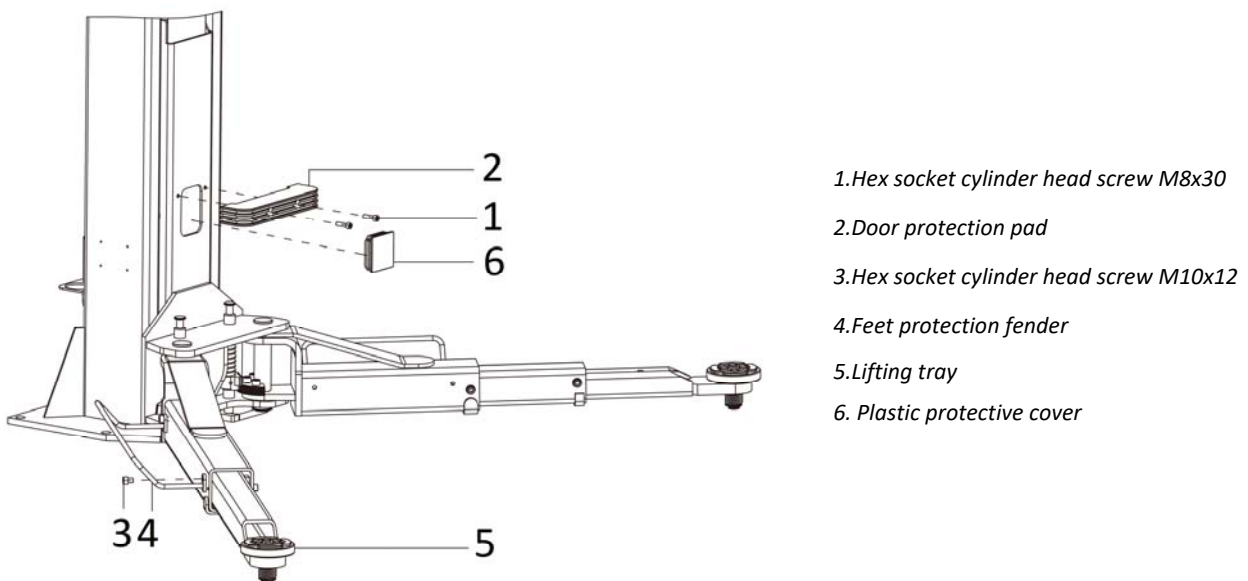
Step 18: Fix door-opening protection pads, feet protection fenders and lifting trays.

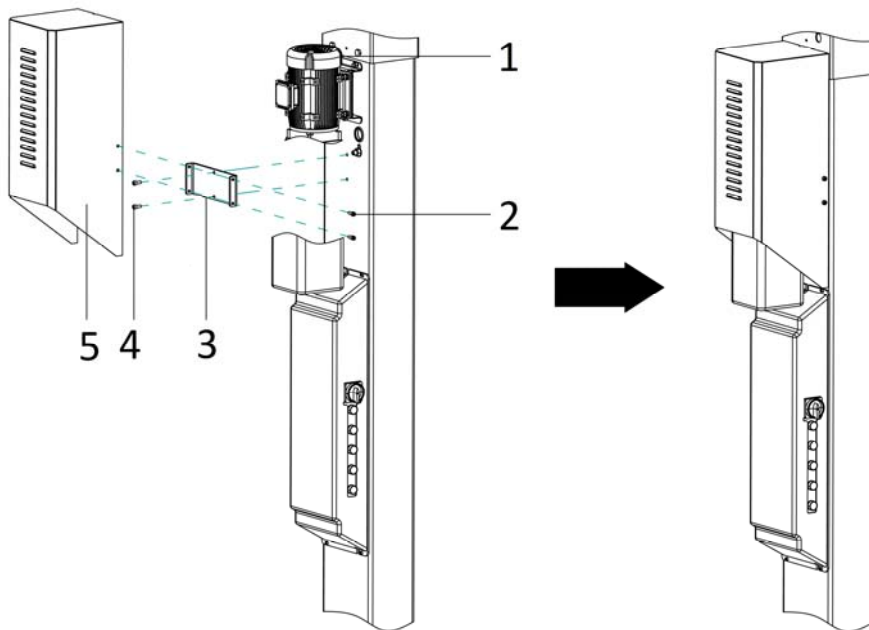
Step 19: Install the motor housing. (Optional)

Pos.	Code	Description	Specification	Qty
1		Power unit	3.5kW	1
2	202110004	Hex socket button head screw	M8*12	4
3	410912142	Holder for the housing	62B-A22-B2-1	1
4	202110004	Hex socket cylinder head screw	M8*12	2
5	614901871	Motor housing	62B-A22-B1-1	1

4.4 Items to be checked after installation.

S/N	Check items	YES	NO
1	Screw torque of expansion bolts: 80-100Nm;	√	
2	Rising speed $\geq 20\text{mm/s}$;	√	
3	Noise with rated load $\leq 75\text{dB(A)}$;	√	
4	Grounding resistance: Not bigger than 4Ω ;	√	
5	Height difference of the two carriages $\leq 5\text{mm}$;	√	
6	Mechanical locks are robust and synchronized when running with rated load ;	√	
7	All control buttons work as "hold to run" ;	√	
8	The limit switches work well;	√	
9	The grounding wire is connected;	√	
10	The carriage rises and lowers smoothly;	√	
11	There is no abnormal noise when run with load;	√	
12	There is no oil leakage when run with load;	√	
13	The expansion bolts, nuts or circlips are well secured or tightened;	√	
14	The max lifting height can be reached;	√	
15	All safety advices, name plate and logos are clear;	√	

OPERATION INSTRUCTIONS

5.1 Precautions

- ONLY authorized persons are permitted in the lift area.
- Do not try to raise the vehicle with excessive length or width. Otherwise there is risk of vehicle falling from lift.
- Inspect the space above and below the load and the loading carrying devices. It shall be free of obstructions before operating.
- Before raising operation, run the lift without load for a complete cycle to ensure it is in good condition.
- Before lifting the vehicle and during all operations on the vehicle, make sure that it is properly stopped by the hand brake.
- Check the vehicle after raising a short distance to ensure that it is correctly and safely positioned.
- It is forbidden for people to stand in the field of motion during raising or lowering movement.
- The load carrying device shall be observed by the operator throughout the motion of the lift.
- Engage the safety locking device before entering under the raised vehicle.
- Avoid excessive rocking of vehicle while on the lift.
- Always use safety stands when moving or installing heavy components.
- Do not climb onto the load or load carrying device when they are raised.

5.2 Operation instructions

To avoid personal injury and property damage, permit only trained personnel to operate the lift. After reviewing these instructions, get familiar with lift controls by running the lift through a few cycles before loading vehicle on lift. Always lift the vehicle using all four adapters. Never raise just one end, one corner or one side of vehicle adapters. The lift must be only used in a static position for lifting and lowering vehicles.

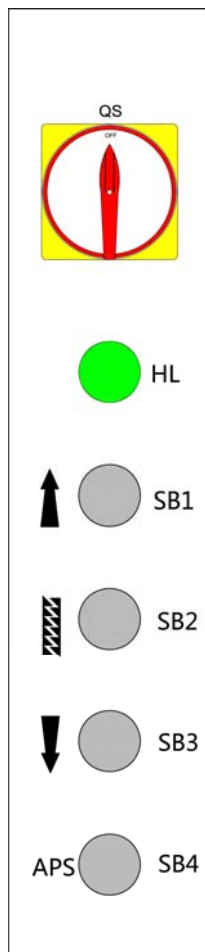

Pos.	Description	Function
QS	Main power switch	Turn on and turn off the main power supply. Also act as an emergency stop.
HL	Power indicator	Illuminate to display the main power is on.
SB1	UP button	Control the rising movement
SB2	Safety lock button	Engage the mechanical safety lock
SB3	DOWN button	Control the lowering movement
SB4	APS button	Push APS button to lower the carriage directly, on condition that the lock is not engaged.

Only one operator is allowed to work around the vehicle lift.

Always engage the safety locking mechanism before any operation on the lifted vehicle.

Do not make any operation on the lifted vehicle at a height under the first latching position (less than 500mm).

Never attempt to lower the lifted vehicle to the bottom when any of its wheel is removed unless you are assured that no damage will occur.

Raise the lift

Make sure vehicle is neither front nor rear heavy and center of balance should be midway between adapters and centered over the lift.

Warning: Always remember to check the engagement of all four swing arm locks and to check all four pick-up adapters for secure contact after a short rise less than 300mm. Otherwise, there could be risks of falling over.

1. Park the vehicle between two posts.
2. Adjust the lifting arms until lifting trays are under the pick-up positions of the vehicle and make sure the gravity of vehicle located over the center of four lifting arms.
3. Turn on the main power switch.
4. Push the "UP" button (SB1) until all four lifting adapters have touched the pick-up positions of vehicle.
5. Keep on raising the vehicle until its wheels have a bit clearance off the ground, stop raising and check again for secure contact.
6. Raise the vehicle to the height expected, push the "Safety Lock" button (SB2) to engage the mechanical safety locking unit. Check again the stability and then do maintenance or repair work underneath.

Lower the lift

When lowering the lift, pay careful attention that all persons and objects are kept clear.

1. Push the "DOWN" button (SB3) on the control box. Meanwhile the lifting arms automatically go upwards for about 2s which releases the mechanical safety locking unit. After that the lift starts descending.
2. When it is fully lowered, position the swing arms and adapters to provide an unobstructed exit before removing vehicle from lift area.
3. Drive the vehicle away.

APS function

In the case the mechanical locking unit is released, push APS button (SB4) for direct lowering.

It enables to efficiently park the lifted vehicle at exact height which is necessary for chassis maintenance, transmission repair or changing. Without this APS system, it is hard and also time-consuming to park exactly as each time you lower the vehicle, the carriage of the lift will rise to release the mechanical safety catch.

TROUBLE SHOOTING

ATTENTION: If the trouble could not be fixed by yourself, please do not hesitate to contact us for help.

We will offer our service at the earliest time we can.

Troubles could be judged and solved much faster when more details or pictures could be provided.

TROUBLES	POSSIBLE CAUSES	SOLUTIONS
Abnormal noise	Abrasion exists on insider surface of the posts.	Grease the inside of the post.
	Trash in the post.	Clear the trash
Motor does not run and will not rise	Loose wire connection.	Check and make a good connection.
	Blown motor.	Replace it.
	Damaged limit switch or its wire connection is loose.	Adjust or replace the limit switch.
Motor runs but will not raise	The motor run reversely.	Check the wire connection.
	Relief valve is not well screwed up or jammed. (Pos.24 in the hydraulic exploded scheme)	Clean or make adjustment
	Damaged gear pump. (Pos.12 in the hydraulic exploded scheme)	Replace it.
	Too low oil level.	Add oil.
	The hose connection is loose.	Tighten it.
	The buffer valve is not well screwed up or jammed. (Pos.25 in the hydraulic exploded scheme)	Clean or make adjustment
	The spool, attached with the solenoid unloading valve, for emergency descent was not screwed tight (Pos.4-1 in the hydraulic exploded scheme).	Tighten the spool. 
Carriages go down slowly after being raised	The oil hose leaks.	Check or replace it.

TROUBLES	POSSIBLE CAUSES	SOLUTIONS
	Untightened oil cylinder.	Replace the seal.
	The non-return valve leaks. (Pos.5 in the hydraulic exploded scheme)	Clean or replace it.
	Unloading valve fails to work well. (Pos.4 in the hydraulic exploded scheme)	Clean or replace it.
	Slack steel rope.	Check and adjust the tightness.
Raising too slow	Jammed oil filter.	Clean or replace it.
	Too low oil level.	Add oil.
	The relief valve is not adjusted to the right position.	Make adjustment.
	Too hot hydraulic oil (above 45°) .	Change the oil.
	Abraded. Seal of the cylinder.	Replace the seal.
	Inside surface of the posts is not well greased.	Add grease.
	The spool, attached with the solenoid unloading valve, for emergency descent was not screwed tight.	Tighten the spool. (Pos.4-1 in the hydraulic exploded scheme)
Lowering too slow	Jammed flow-restrictive valve. (Pos.23 in the hydraulic exploded scheme)	Clean or replace it.
	Dirty hydraulic oil.	Change the oil.
	Jammed hose leakage protective valve. (Pos.13 in the hydraulic scheme)	Clean it.
	Jammed oil hose.	Replace it.
The steel rope is abraded	No grease at installation or out of lifetime.	Replace it.

INSPECTION AND MAINTENANCE

Following are requirements for routine maintenance. Easy and low cost routine maintenance can ensure the lift work normally and safely. The plan for routine inspection and maintenance shall be worked out by referring to the following list as well as according to the regulations of the local authorities.

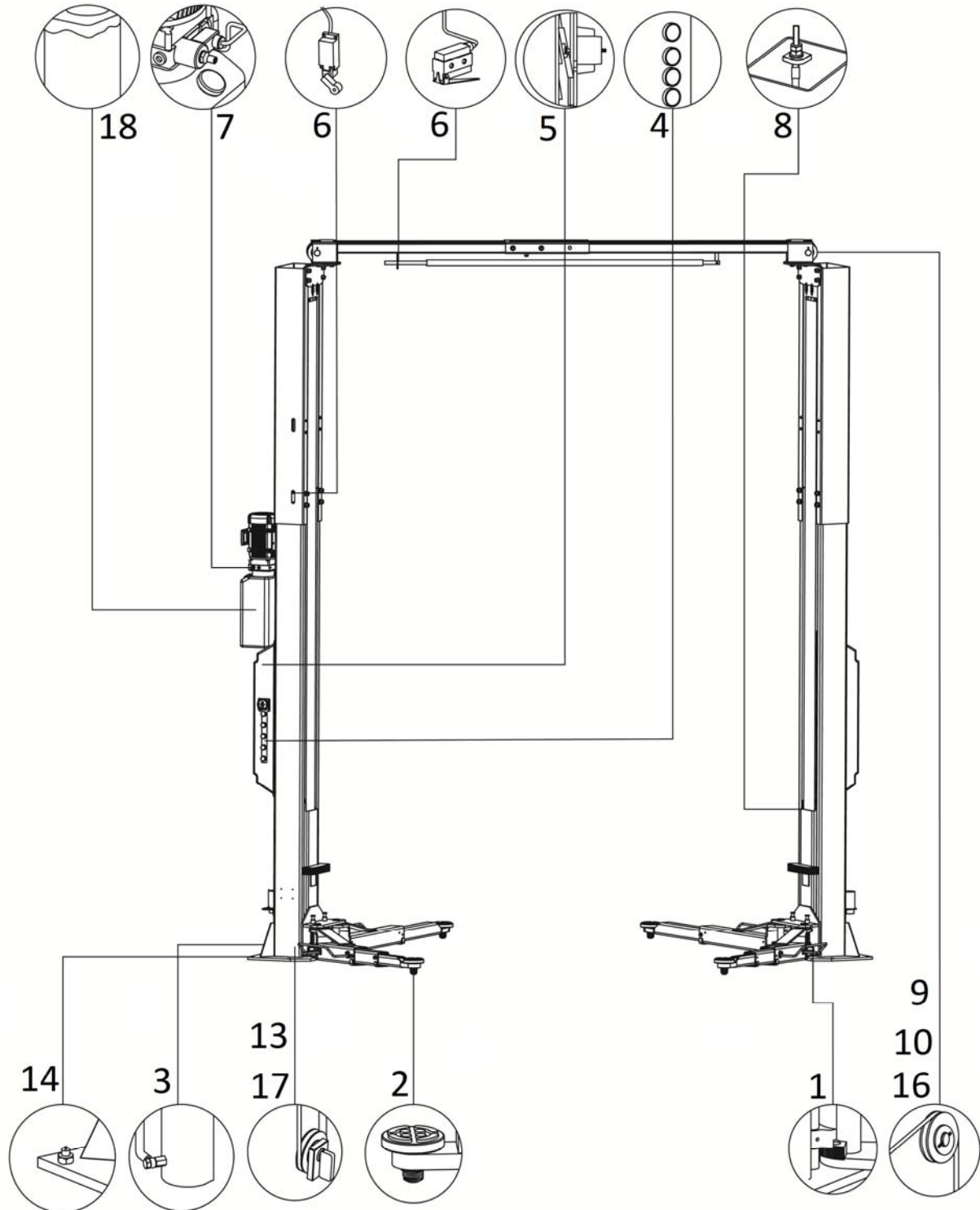

Pos.	Components	Methods	Period
1	Swing arm locking units	Push the UP button to raise the lifting arms and check if four swing arms are locked into position.	Every day
2	Lifting adapter	Check if it can screw UP and DOWN smoothly. Add grease onto the swivel when necessary. Inspect the rubber pads and clean off any objects that may cause sliding or damage.	Every day
3	Cylinder and oil hose connectors	Inspect to ensure no leakage before using the lift.	Every day
4	Control buttons	Check if control buttons work as "hold- to -run " and check if they work as the function indicated.	Every day
5	Mechanical safety locking unit	Check if both mechanical catches can engage and disengage effectively by pushing control buttons.	Every day
6	Limit switch	Use proper means to activate the switch and push UP button to check if the carriage stop rising	Every day
7	Unloading valve	Inspect if the valve leaks. Clean or change the valve in case of leakage.	Every day
8	Steel ropes	Check the synchronization of both carriages and adjust the tension of the ropes when asynchronization is unacceptable.	Every day
9	Bushing of the upside pulley	Lubricate the bushing with NO.1 lithium based grease.	Every 3 months
10	Steel ropes	Lubricate the rope with NO.1 lithium based grease. It is advised to change with new steel ropes every 3 years. (Not obligatory if the parts are in good condition) Stop using the lift and replace the rope immediately on condition that there are ten or more broken wires on a rope.	Every 3 months
11	Running path for carriages inside the post	Lubricate the path with NO.1 lithium based grease. No obstruction on the path.	Every 3 months
13	Bushing of the downside pulley	Lubricate the bushing with NO.1 lithium based grease.	Every 3 months
14	Expansion bolts	Check with torque spanner. For M18 bolt ,the torque is no less than 80N.m	Every 3 months
	Whole Lift	Running the lift for several cycles with and without rated load. The lift can run steadily and smoothly with no abnormal noise.	Every 3 months
16	Bushing of the upside pulley	Slacken the steel rope and dismantle the pulley assembly. Measure the abrasive clearance and change the bushing if the clearance is bigger than 0.5mm.	Every year
17	Bushing of the downside pulley	Slacken the steel rope and dismantle the pulley assembly. Measure the abrasive clearance and change the bushing if the clearance is bigger than 0.5mm.	Every year
18	Hydraulic oil	Change the oil 6 months after initial use and once per year thereafter. Inspect the hydraulic oil and change the oil if the oil becomes black or there is dirt in the oil tank.	Every year

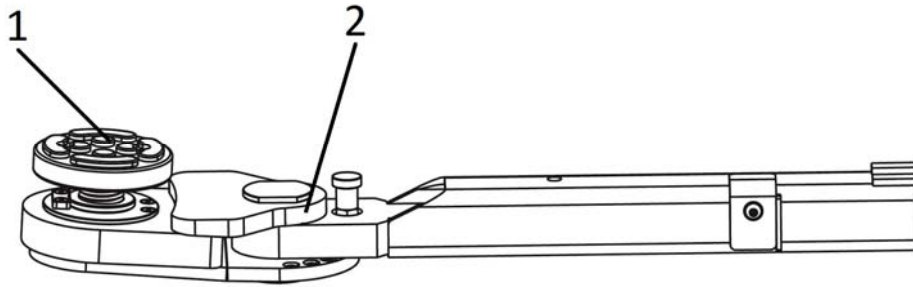
Elbow extension

Pos.	Components	Methods	Period
1	Lifting adapter	Check if it can screw UP and DOWN smoothly. Add grease onto the swivel when necessary. Inspect the rubber pads and clean off any objects that may cause sliding or damage.	Every day
2	Elbow extension	Check if it can be rotated smoothly. Lubricate the elbow extension with NO.1 lithium based grease.	Every 3 months

If users stick to the above maintenance requirements, the lift will always keep a good working condition and its service life could be extended.

Annex 1, Floor plan

General requirements:

The lift is designed for indoor installation only. Do not expose the lift to rain, snow or excessive moisture. Do not use the lift near explosives or open areas containing inflammable liquids.

The space requirement specified in the below scheme is for reference only.

There must be sufficient space for driving and lifting vehicles and enough safety distance shall be reserved according to the regulations of the local authorities. It is advised to reserve a clearance of at least 1 meter between the lift and fixed elements (e.g. wall) in all lifting positions.

C25/C30 concrete foundation with a minimum thickness of 200mm.

Surface under the base plate of each post: Horizontal and even (Gradients max. 0.5 %)

Newly built concrete ground must be older than 20days.

In mm.

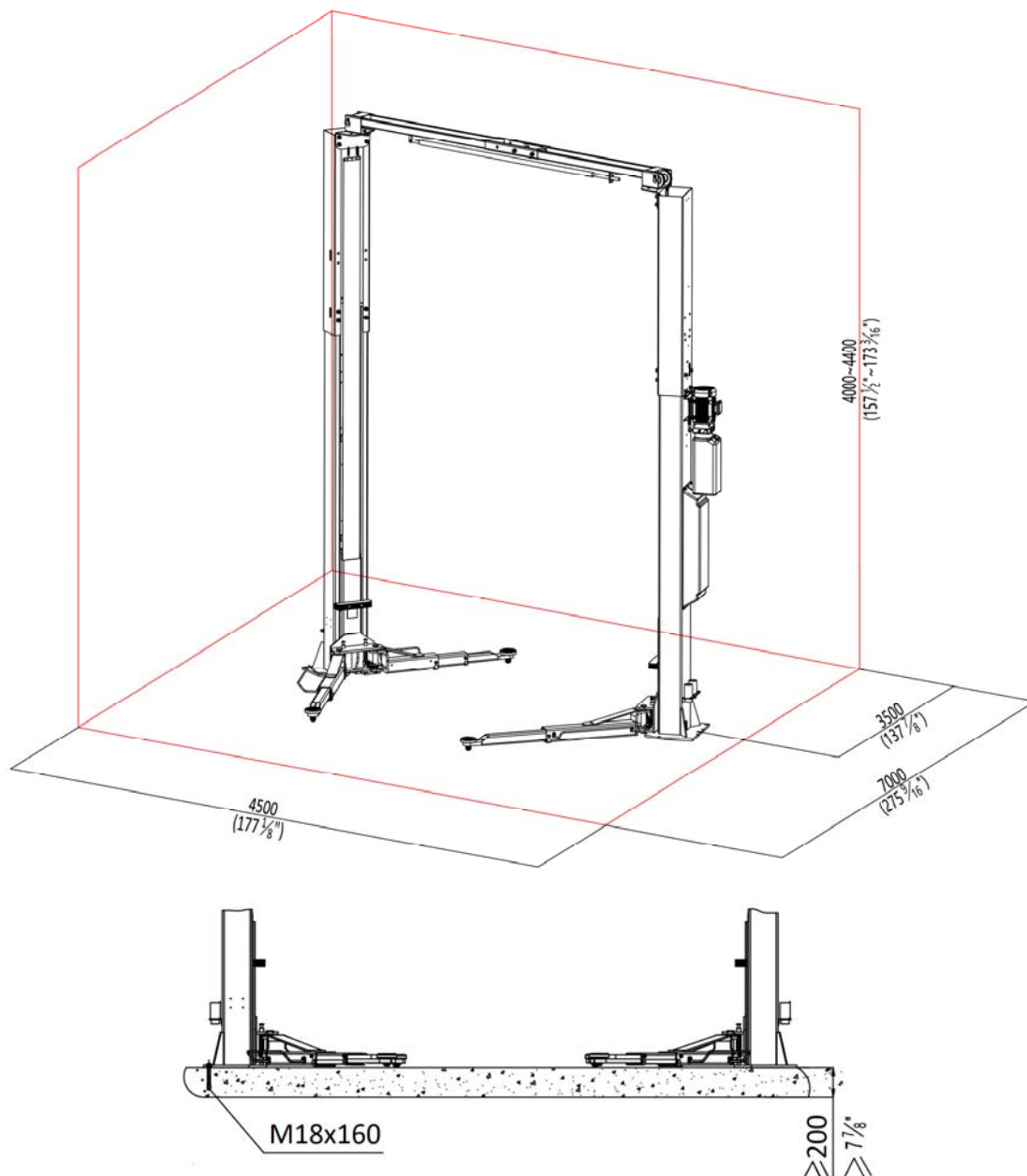

Base layout for asymmetrical column configuration

Check the angle of the two baseplates using a straight line. The line shall go through both openings reserved on the baseplates.

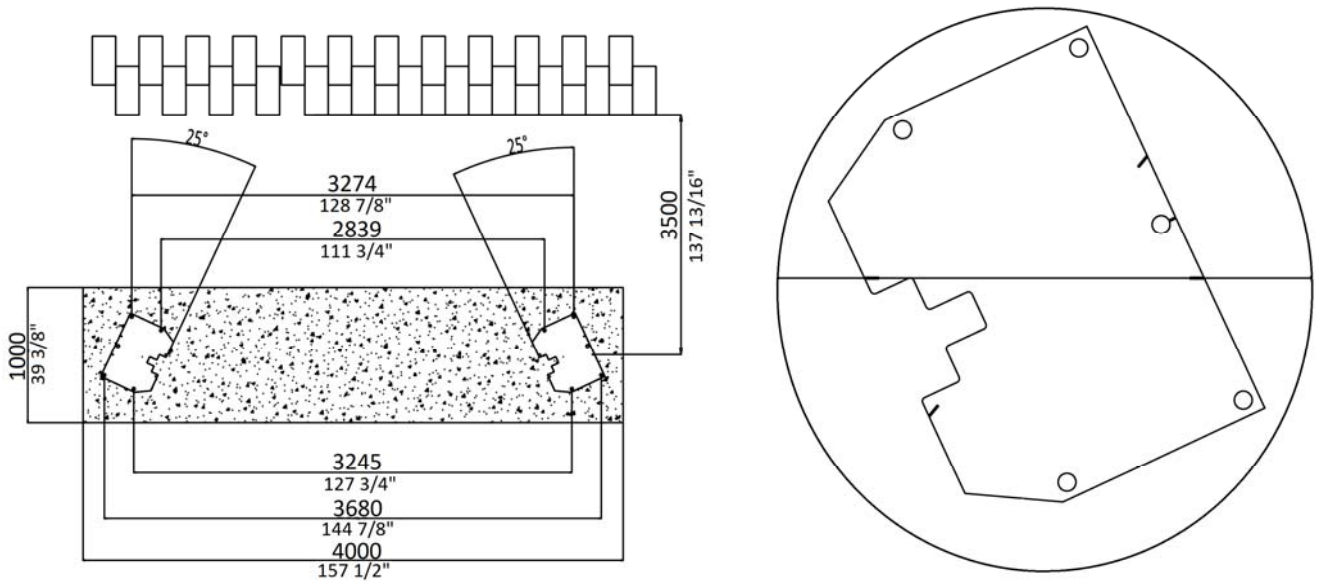

Base layout for symmetrical column configuration

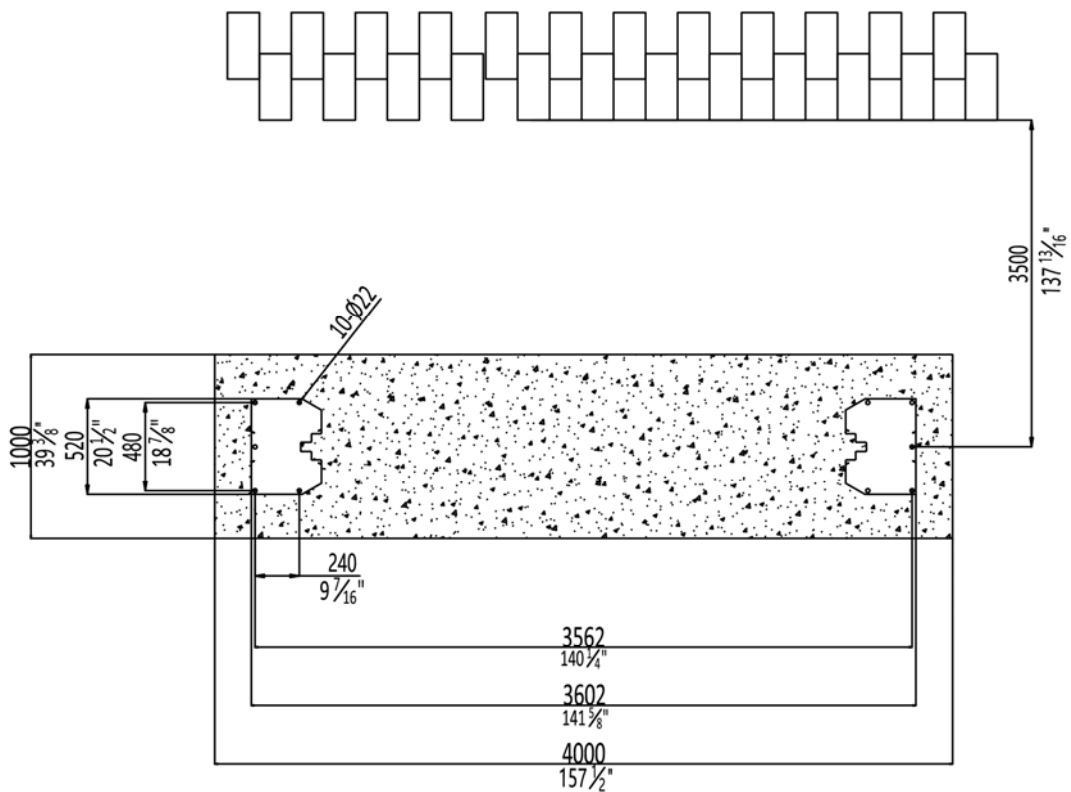

Annex 2, Electrical diagrams and parts list

(Note: For the specific requirements on voltage, the actual voltage of your lift may differ with the following diagram)

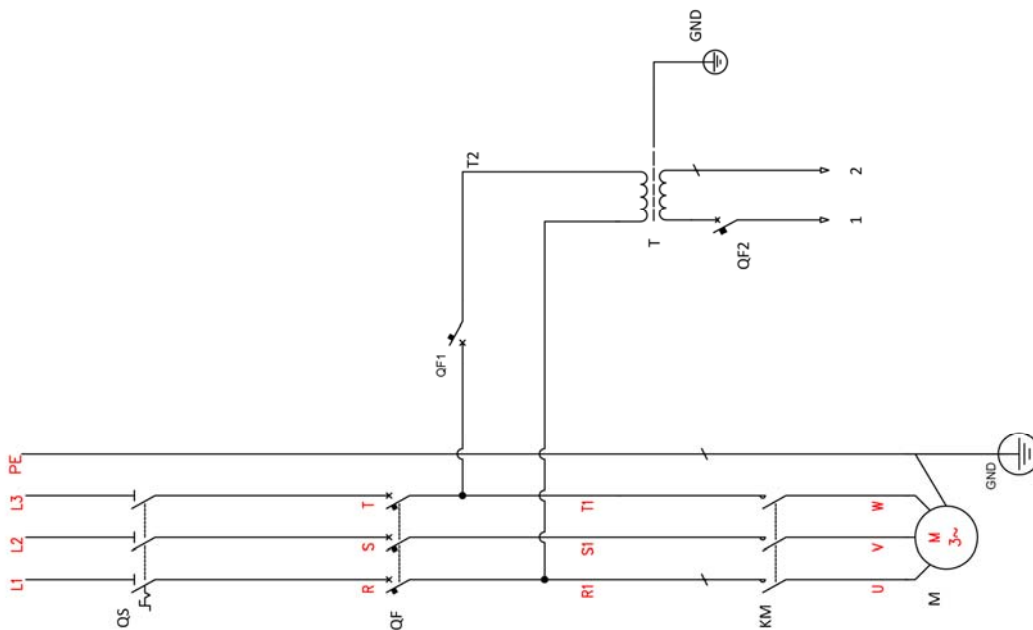
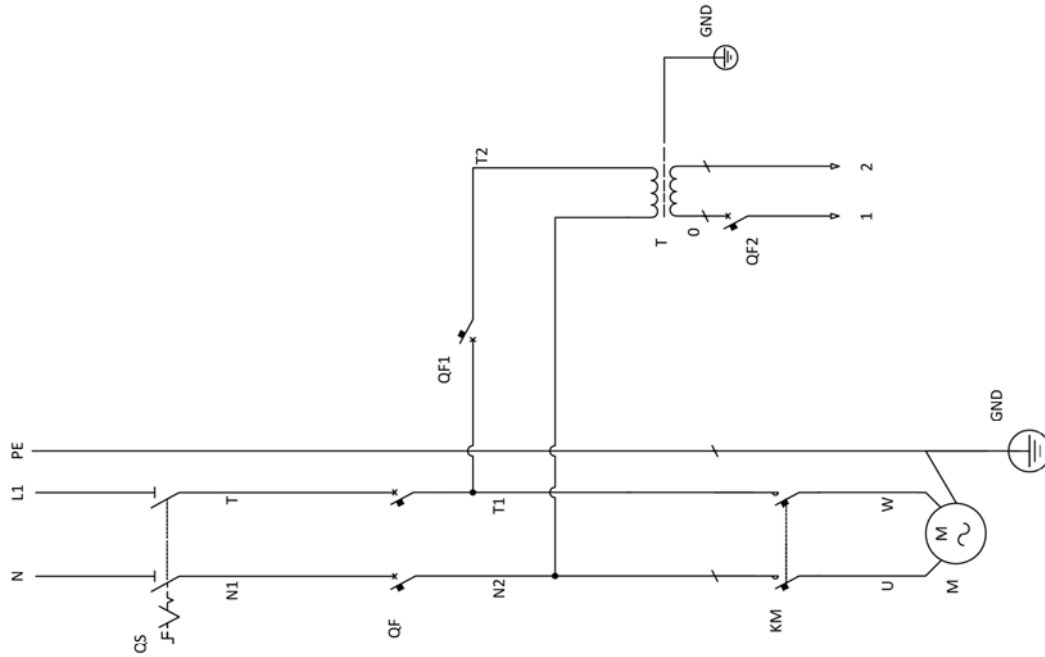

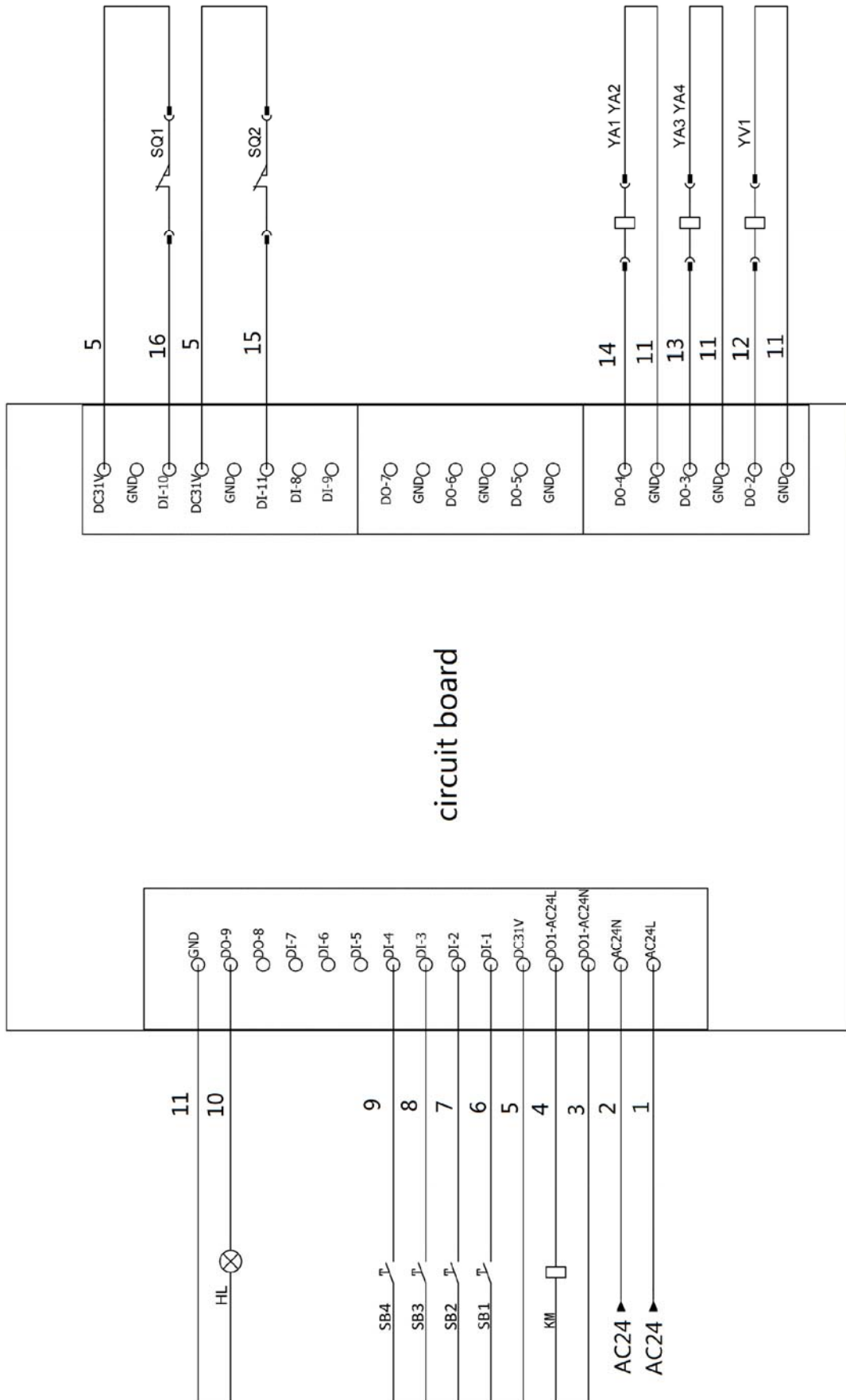

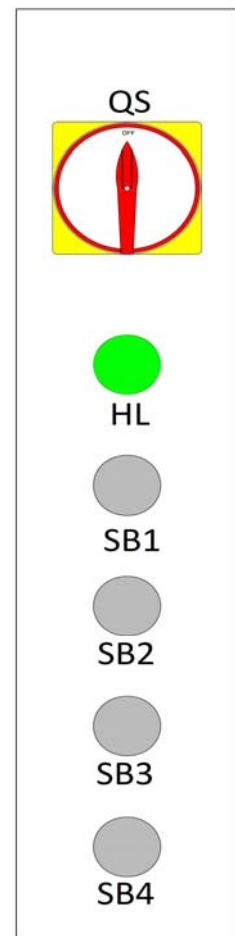
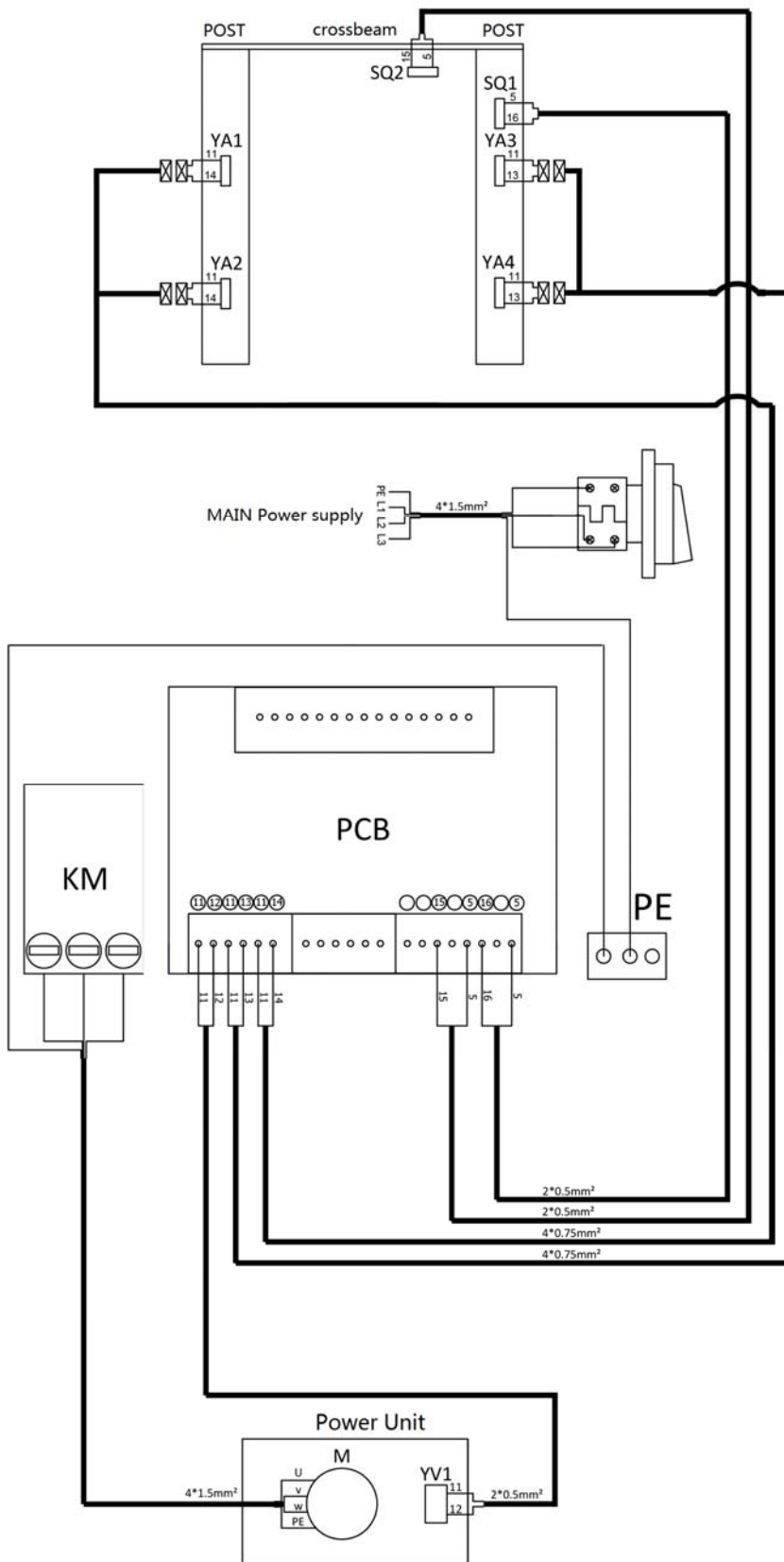

SQ1: Limit switch for maximum height

SQ2: Limit switch for roof protection

YA1-YA4: Electromagnet

YV1: Solenoid valve for descending

Supply cord	Yellow-Green	Blue	Other colors
3 wires	Earth wire	Neutral wire	Phase wire
5 wires	Earth wire	Neutral wire	Phase wire
Supply cord	Yellow-Green	Other colors	
4 wires	Earth wire	Phase wire	

Pos.	Code	Description	Qty
T	320102013	Transformer (dual 380V220V)	1
T	320102014	Transformer (dual 400V230V)	1
T	320102015	Transformer (dual 415V240V)	1
QF	320801003	Circuit breaker	1
QF1	320803003	Circuit breaker	1
QF2	320803006	Circuit breaker	1
KM	320901011	AC contactor	1
QS	320304001	Main switch	1
SB1 SB2 SB3 SB4	320401042	Button	4
SQ1	320301011	Limit switch	1
SQ2	320301002	Limit switch	1
YA1 YA2 YA3 YA4	330310005	Electromagnet	4
HL	321800001	Power indicator	1
	791130035	Circuit board	1

**NOTE: For power supply of other voltages, the transformers are different.
Please check with our customers service people when order spare parts.**

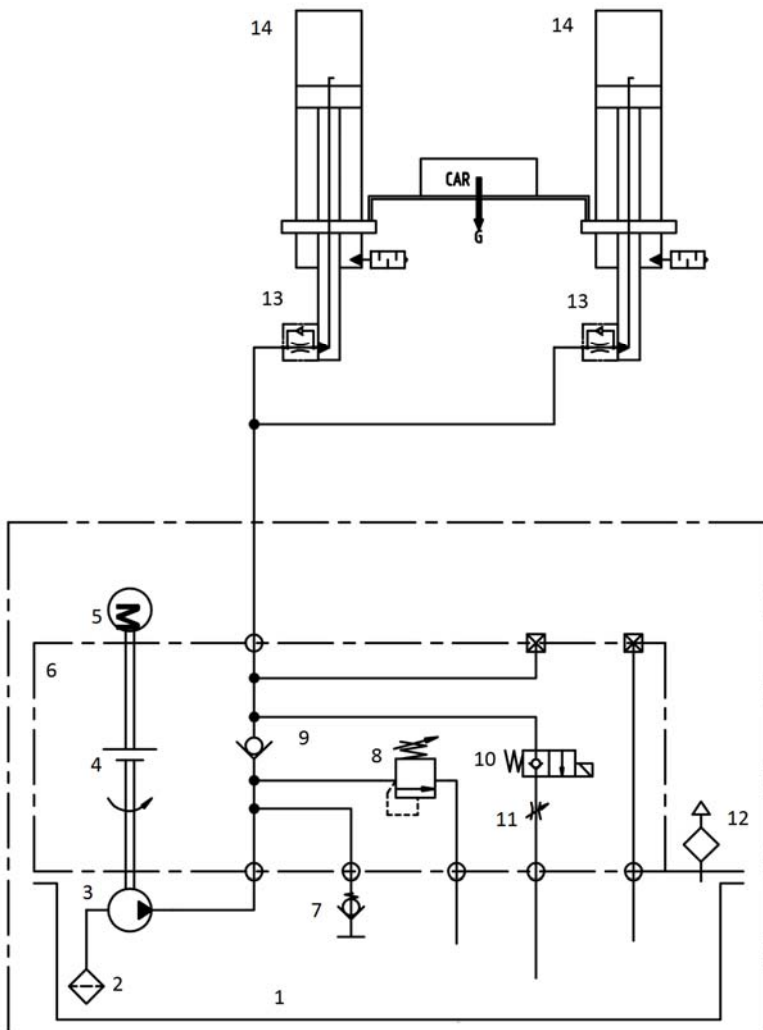
Annex 3, Hydraulic diagrams and parts list

- 1.oil tank
- 2.oil sucking filter
- 3.gear pump
- 4.coupling
- 5.motor
- 6.hydraulic block
- 7.buffer valve
- 8.relief valve
- 9.non-return valve
- 10.solenoid valve for descending
- 11.flow-restrictive valve
- 12.lid of oil tank (breather)
- 13.hose leakage protective valve
- 14.oil cylinder

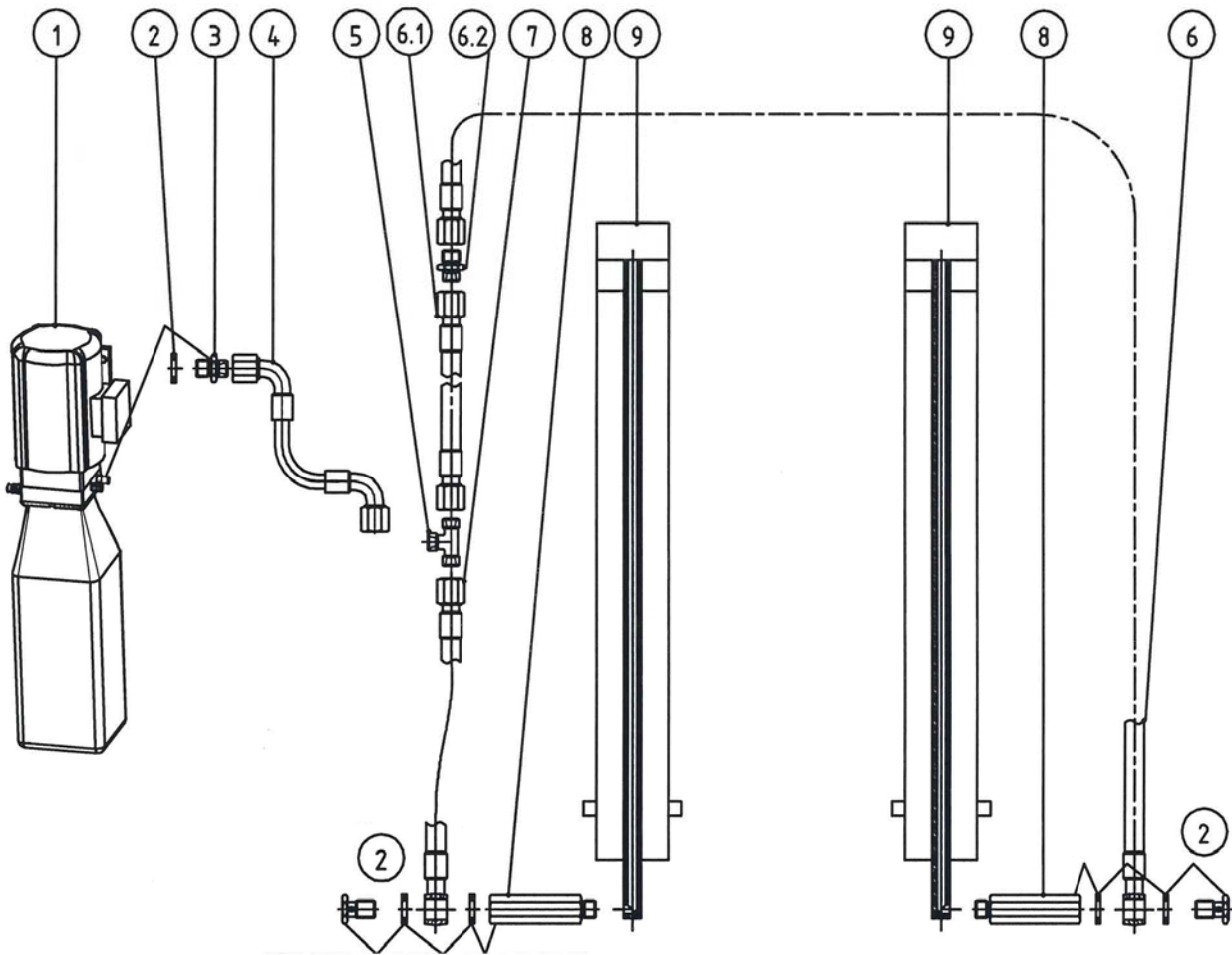

Pos.	Code	Description	Specification	Qty
1		Power unit	2.2kW/3.5kW	1
2	207103025	Composite washer	13.7*20*1.5	5
3	310101008	Shift connector	M14*1.5-G1/4 inside cone	1
4	624008046	Rubber oil hose 1	Ø8.,L=320mm	1
5	615006003	Three way connector	6214E-A4-B4	1
6	624002025B	Rubber oil hose 3	L=8625mm	1
6.1	624008246	Rubber oil hose 2 (only usable for a total height of 4300mm)	L=840mm	1
6.2	410210191	Straight connector (only usable for a total height of 4300mm)	6603B-A9-B8	1
7	624002004B	Rubber oil hose 4	L=2265mm	1
8	615015003	Composite connector	6255E-A7-B7	2
9	625000013	Oil cylinder	YG5060-38-1800	2
9	625000013B	Oil cylinder (Replace 625000013 since April 11 th , 2025)	YG5060-38-1800	2

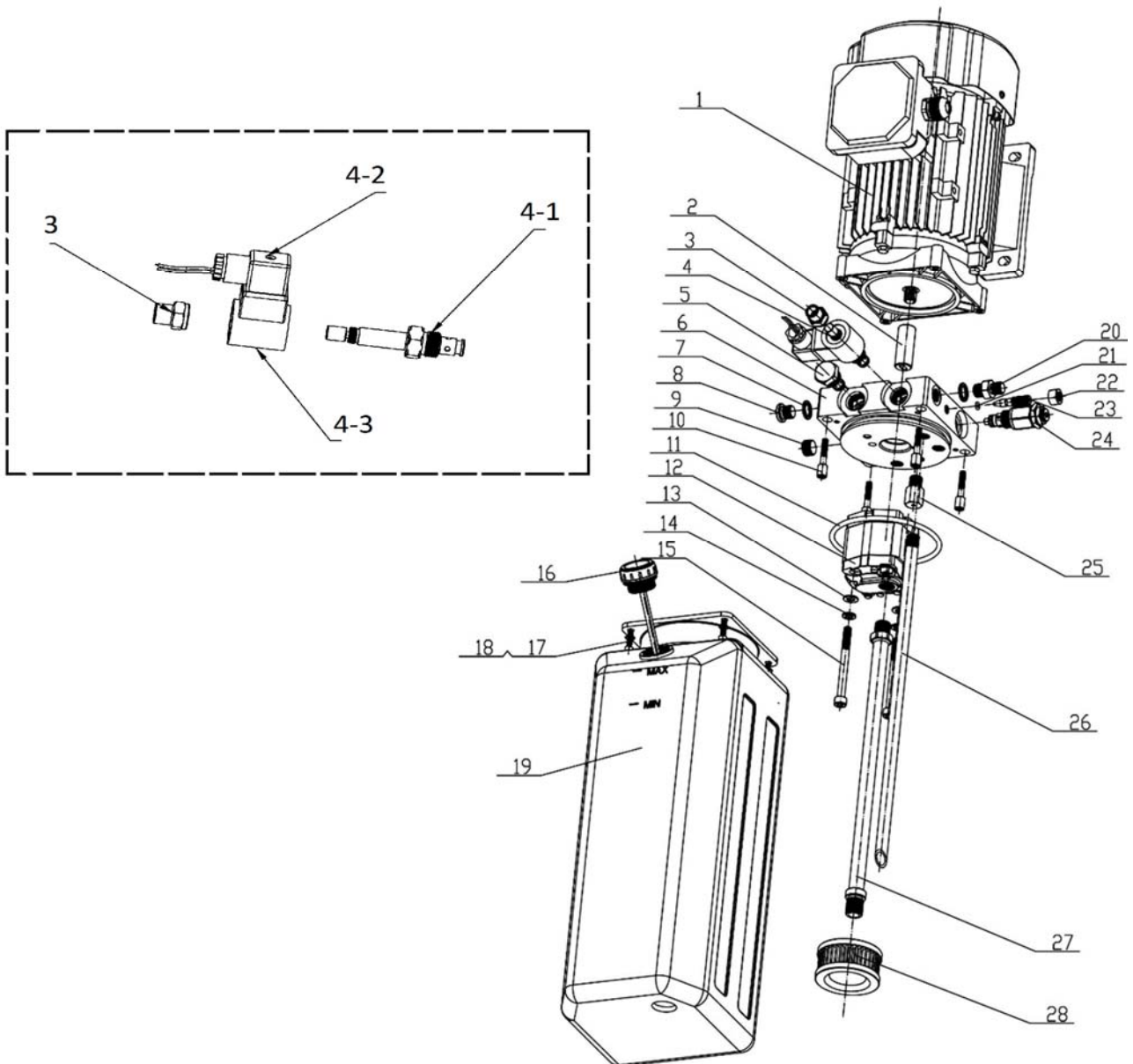

Pos.	Code	Descriptions	Specification	Qty
1+2	320201001+330404007	Motor + Coupling (46mm)	220V-2.2kW -1Ph-50Hz-2P	1
1+2	320201011++330404007	Motor + Coupling (46mm)	220V-2.2KW-1Ph-60Hz-2P	1
1+2	320204304+330404006	Motor + Coupling (48mm)	400V-230V-3.5kW-3Ph-50Hz-2P	1
1+2	320204302+330404006	Motor + Coupling (48mm)	380V-220V-3.5kW-3Ph-50Hz-2P	1
1+2	320204306+ 330404013	Motor + Coupling (54mm)	415V-3.5kW -3Ph-50Hz-2P	1
3	203204102	Locking nut	FHLM-1/2-20UNF	1
4	791150005	Solenoid valve assembly (include part No.3, 4-1,4-2 and 4-3)	DC24V	1
4-1	330311005	Valve spool	24DC(Keta) (LSV-08-2NCP-M-2H)	1
4-2	330308032	Solenoid plug	DIN43650-DC	1
4-3	330308031	Solenoid coil	LC2-0-C-2H,24VDC-	1

Pos.	Code	Descriptions	Specification	Qty
5	330302008	Non-return valve	YBZ-E2D3I1/1-03	1
6	330101113	Hydraulic block	LBZ-T2BK-8	1
7	207103019	Composite washer	M14	2
8	310101008	Transition connector	M14*1.5-G1/4 inside cone	1
9	210101014	Plug	Z3/8	1
10	201101100	Bolt	M6*50 (NLJLD)	4
11	207101098	O-ring	109*5.3	1
12	330201005	Gear pump(2.2kW, 60Hz)	CBK-F220/CBK-2.1F	1
	330201006	Gear pump(2.2kW, 50Hz)	CBK-F225/CBK-2.5F	1
	330201008	Gear pump(3.5kW)	CBK-F242	1
13	204101005	Washer	M8	4
14	204201013	Spring washer	M8	2
15	202109072	Hex socket cylinder head screw (with spring washer)	M8*85	2
16	330502013	Lid of oil tank (breather)	YBZ-BT-M30*2-B	1
17	202109144	Bolt	M5*18	4
18	204101003	Flat washer	M5	4
19	330405051	Plastic oil tank	10L-SLYX-10L-L-BX	1
20	210101013	Plug	M14*1.5	1
21	207101099	O-ring	5*1.8	4
22	203102003	Hex nut (thin, 6mm)	M10*1	1
23	330305015	Flow-restrictive valve	YBZ-E2D3I1/1-11A	2
24	330304007	Relief valve	YF08-40	1
25	330301003	Buffer valve	HCF-Z1/4	1
26	330402001	Oil-returning pipe	YH-D	1
27	330401013	Oil-sucking pipe	YBZ-SJYG350	1
28	330403001	Oil-sucking filter	YG-C	1

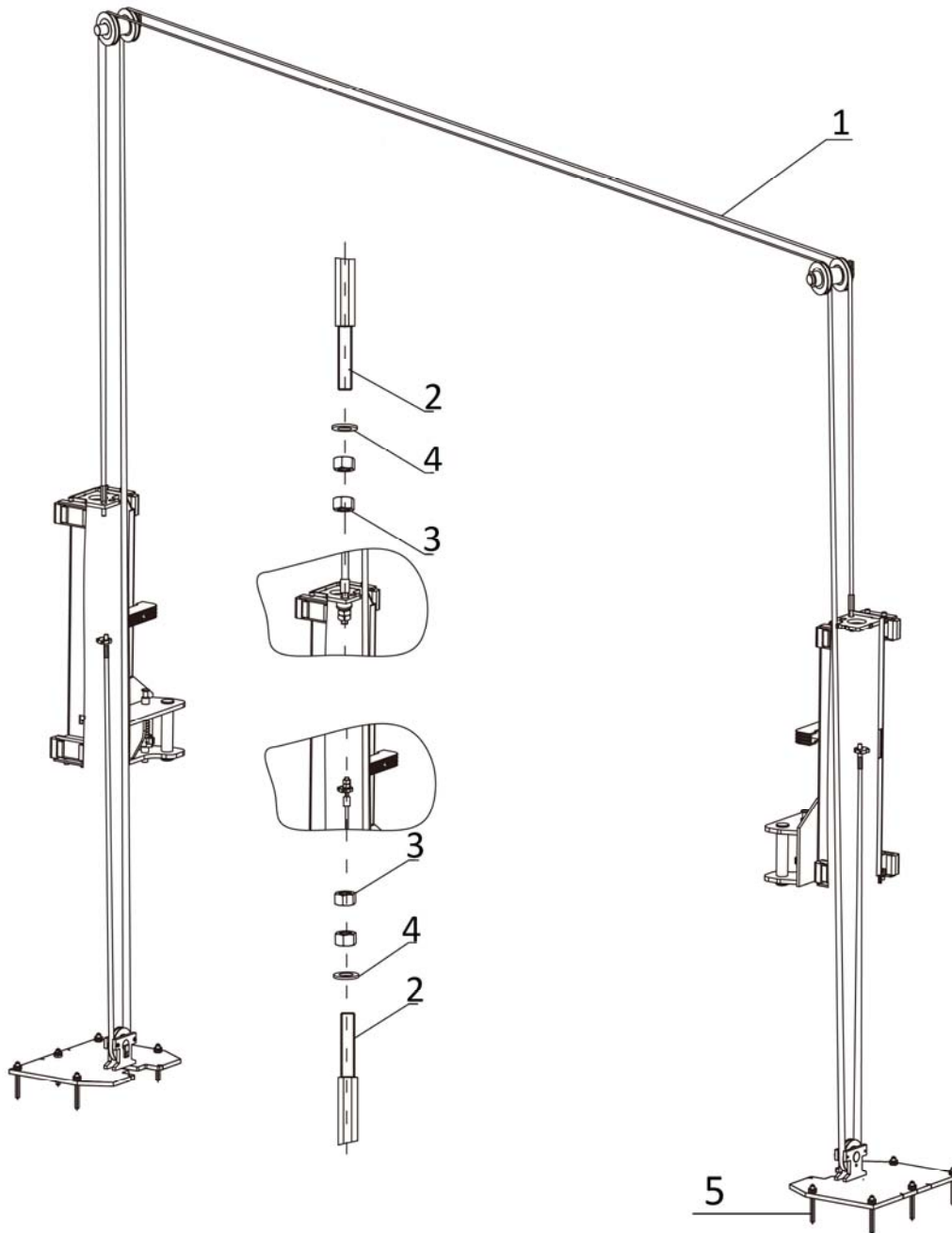
Annex 4 , Mechanically exploded drawings and parts list

Pos.	Code	Description	Specification	Qty
1	615068742	Steel rope	62C-A22 L=11260MM Ø9.3	2
2	615068742	Steel rope	62C-A22 L=11260MM Ø9.3	2
3	203101009	Hex nut	M16	8
4	204101009	Flat washer	M16	4
5	201201007	Expansion bolt	M18*160	10

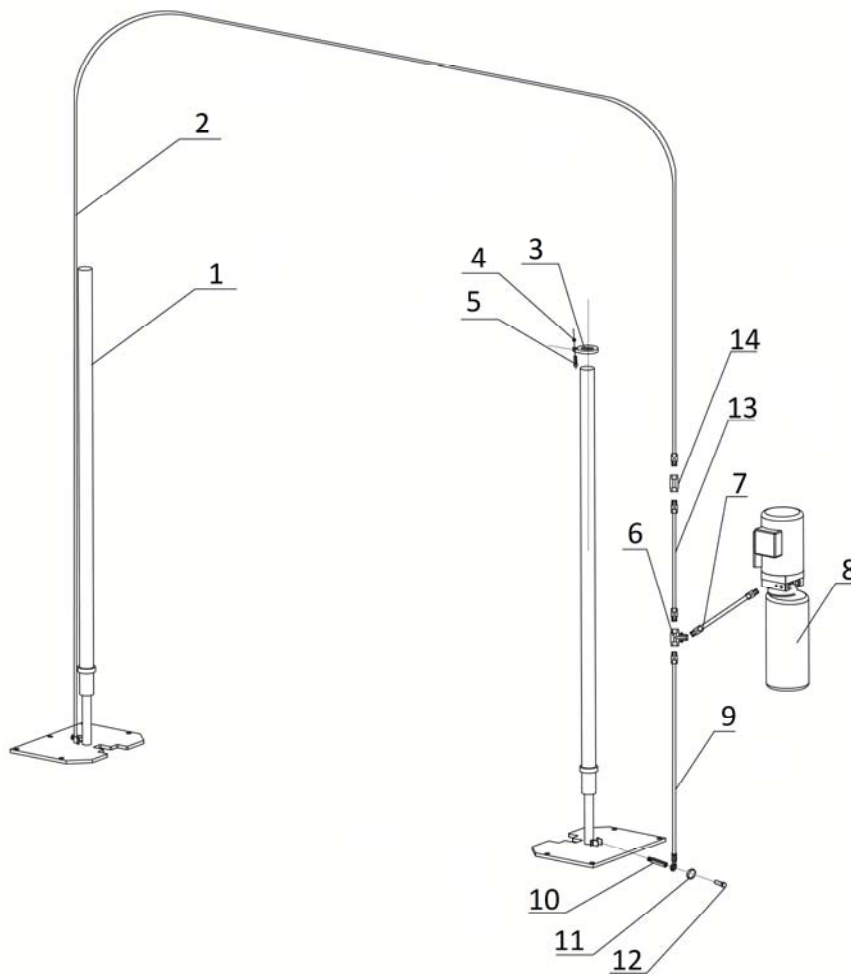

Pos.	Code	Description	Specification	Qty
1	625000013	Oil cylinder	YG5060-38-1800	2
1	625000013B	Oil cylinder (Replace 625000013 since April 11th, 2025)	YG5060-38-1800	2
2	624002025B	Rubber oil hose 3	L=8625mm	1
3	410170101B	Ring for cylinder fixation	6264-A24-B1	2
4	203103005	Hex locking nut	M6	2
5	202109024	Hex head full swivel screw	M6*35	2
6	615006003	Three way connector	6214E-A4-B4	1
7	624008046	Rubber oil hose 1	L=320mm	1
8		Power unit	2.2kW/3.5kW	1
9	624002004B	Rubber oil hose 4	L=2265mm	1
10	615015003	Composite connector	6255E-A7-B7	2
11	207103025	Composite washer	13.7*20.00*1.50(BS224)	2
12	615015003	Composite connector	6255E-A7-B7	2
13	624008246	Rubber oil hose 2 (optional, only usable for a total height of 4300mm)	L=840mm	1
14	410210191	Straight connector (optional, only usable for a total height of 4300mm)	6603B-A9-B8	1

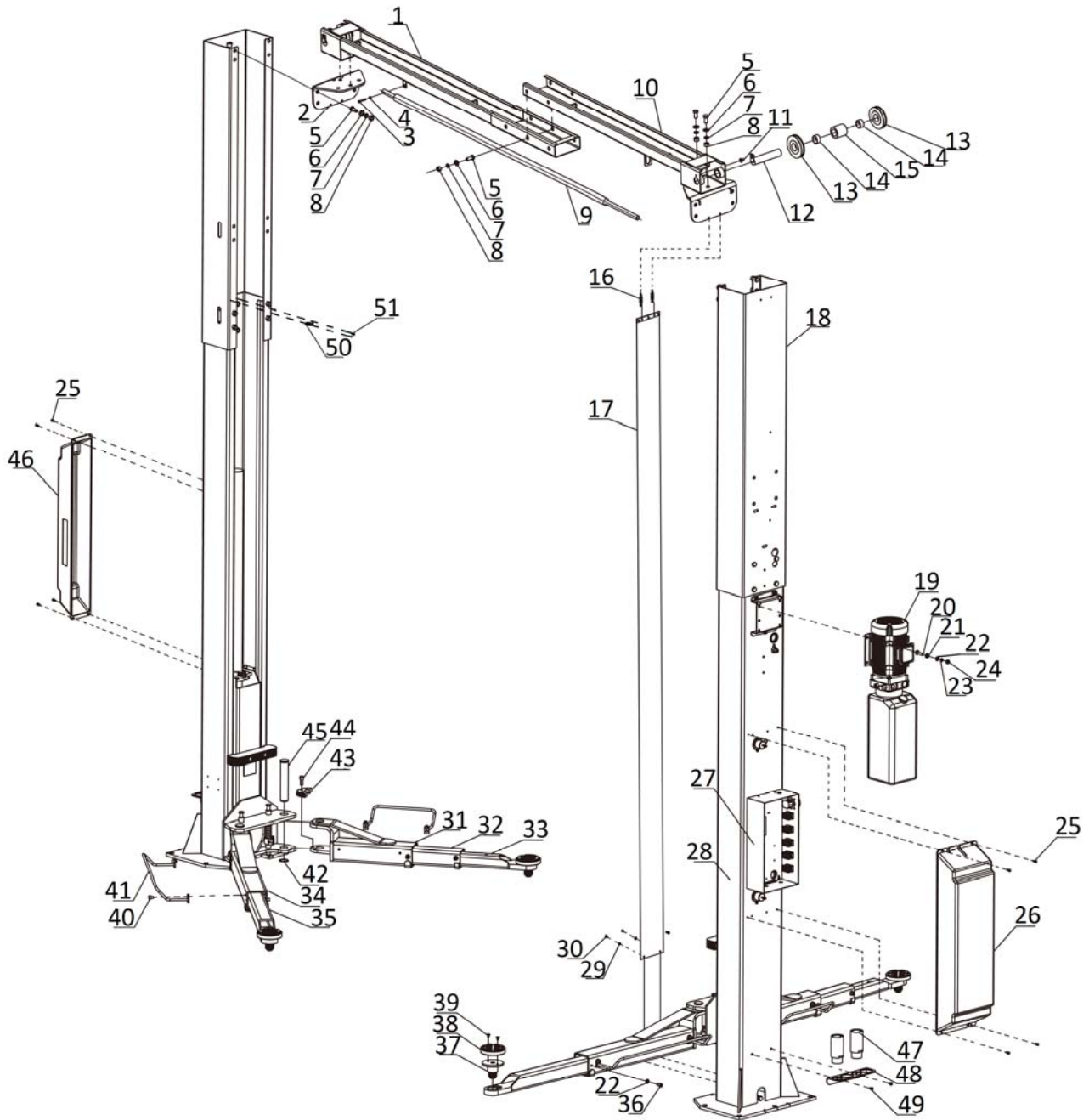

Pos.	Code	Description	Specification	Qty
1	614901691	Crossbeam(out)	62C-A21-B1-42T-EA	1
2	614901732	Connection plate	62C-A21-B3-42T-EA	2
3	202109024	Hex head full swivel screw	M6X35-GB70_1	1
4	203103005	Hex locking nut	M6-GB889	2
5	201102035	Hex head full swivel screw	M14X30-GB5783	33
6	204101008	Flat washer	D14-GB95	33
7	204201007	Spring washer	D14-GB93	33
8	203101008	Hex nut	M14-GB6170	33

Pos.	Code	Description	Specification	Qty
9	420060010	Black foam tube	6214E-A21-B3	1
10	614901692	Crossbeam (in)	62C-A21-B2-42T-EA	1
11	202111008	Hex socket flat head screw	M10X16-GB70_3	2
12	612901718	Upside pulley shaft assembly	62C-A21-B3	2
13	410902109	Pulley	C9Z-A1-B2	6
14	205101101	Bearing	3520-SF-1X	6
15	410911631	Space sheath	62C-A21-B4	2
16	410274470C	Spring	6435B-A4-B30	4
17	615068743	Chain protection cloth (usable for a total height of 4300mm)	62C-A1-B5,L=3875mm	2
17	615068647	Chain protection cloth (usable for a total height of 3867mm)	62C-A1-B3,L=3440mm	2
18	410912171	Extending post	62CV3-A2-B1-C1	2
19		Power unit	2.2kW/3.5kW	1
20	201103004	Hex head full swivel screw	M10X35-GB5783	4
21	420040010	Anti-shock washer	6254E-A23	4
22	204101006	Flat washer	D10-GB95	26
23	204201005	Spring washer	D10-GB93	23
24	203101006	Hex nut	M10-GB6170	7
25	202109019	Hex socket cylinder head screw	M6X12-GB70_1	8
26	420680117	Protective cover 1 on the power side post	62B-A17	1
27	420680177	Main control box frame	62C-A20-42T-EA	1
28	614901948	Post (35T)	62C-A4-B1-35T-EA	2
28	614901757	Post (42T)	62C-A4-B1-42T-EA	2
29	204101004	Flat washer	D6-GB95	4
30	202101027	Cross socket cap head screw	M6X8-GB818	4
31	614004007C	The first stage of short arm	6254E-A27-B1	2
32	614004009C	Short retractable mid-arm	6254E-A27-B2	2
33	614004011C	Short retractable arm	6254E-A27-B3	2
34	614004005B	The first stage of long arm	6254E-A7-B1	2
35	614901362	Long retractable arm	6254E-A7-B3-1	2
36	202109040	Hex socket cylinder head screw	M10X16-GB70_1	6
37	615004003D	Lifting tray assembly(round)	6254E-A7-B4	4
38	420040250	Round lifting pad	6254E-A7-B4-C4	4
39	202111004	Hex socket flat head screw	M8X12-GB70_3	8
40	202110018	Hex socket cylinder head screw	M10X12-GB70_1	8
41	614004014B	Long fender	6254E-A7-B5	2
42	204301013	Circlip	D38-GB894	4
43	410901074	Semi-Teeth block	6254E-A7-B8	4

Pos.	Code	Description	Specification	Qty
44	202109085	Hex socket cylinder head screw	M12X30-GB70_1	12
45	410049031B	Pin shaft	6254E-A12	4
46	420047160B	Protective cover 2 on the secondary post	62B-A16	1
47	612004003B	Height adapter	6254E-A11	4
48	410901744	Holder for the height adapter	6254E-A1-B1-C6-V0	2
49	202110004	Hex socket button head screw	M8X12-GB70_2	4
50	208107032	Fixing fitting	CZ3452-D22	2
51	202109017	Hex socket cylinder head screw	M6X8-GB70_1	4

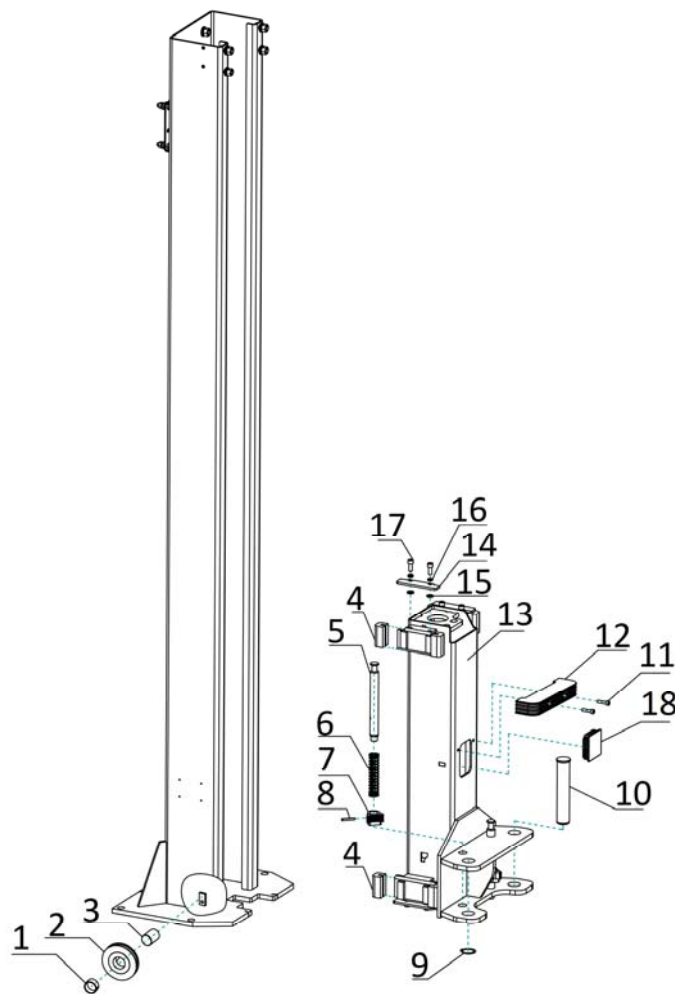

Pos.	Code	Description	Specification	Qty
1	205101101	Bearing	3520-SF-1X	2
2	410902109	Pulley	C9Z-A1-B2	2
3	410540080	Downside pulley shaft	C12-A1-B3-C1	2
4	420680083	Slider	C9Z-A1-B5	16
5	410902001B	Pulling rod	6254E-A2-B1-C1-1	4
6	410150121	Pressure spring	6254E-A2-B4	4
7	410901075	Teeth block	6254E-A2-B9	4

Pos.	Code	Description	Specification	Qty
8	206102013	Elastic post pin	D6X40-GB879	4
9	204301013	Circlip	D38-GB894	4
10	410049031B	Pin shaft	6254E-A12	4
11	202109031	Hex socket cylinder head screw	M8X30-GB70_1	4
12	420680124	Protection rubber pad	62B-A3-B11	2
13	614901880	Carriage	62C-A5-B1-42T-EA	2
14	410912173	Retain plate for sliders	62B-A7-B9-C2	8
15	204101006	Flat washer	D10-GB95	16
16	204201005	Spring washer	D10-GB93	16
17	202110012	Hex socket cylinder head screw	M10X25-GB70_2	16
18	210101018	Plastic protective cover	80X80MM	2

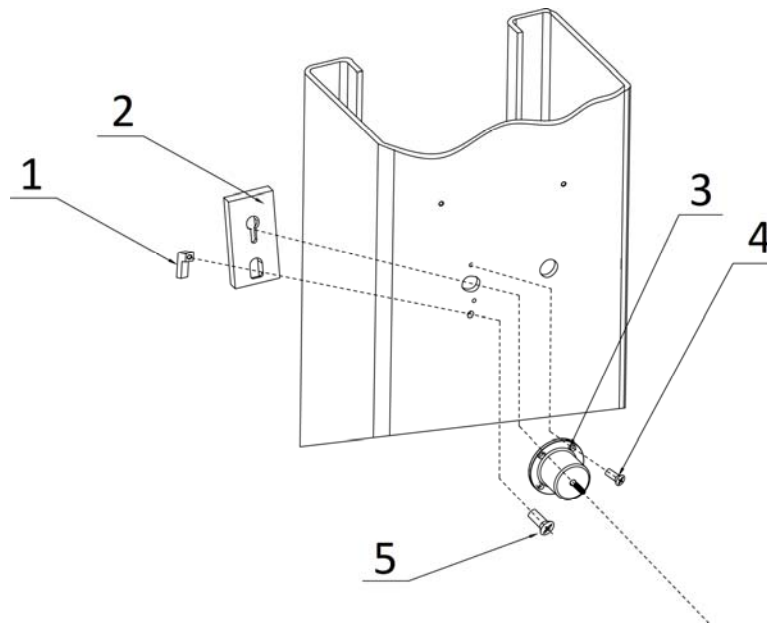

Pos.	Code	Description	Specification	Qty
1	410040071	Orientation block	6254E-A17	4
2	410040061	Safety locking plate	6254E-A13	4
3	330310005	Electromagnet	6254E-A14	4
4	202109017	Hex socket cylinder head screw	M6*8	8
5	202109020	Hex socket cylinder head screw	M6*15	4

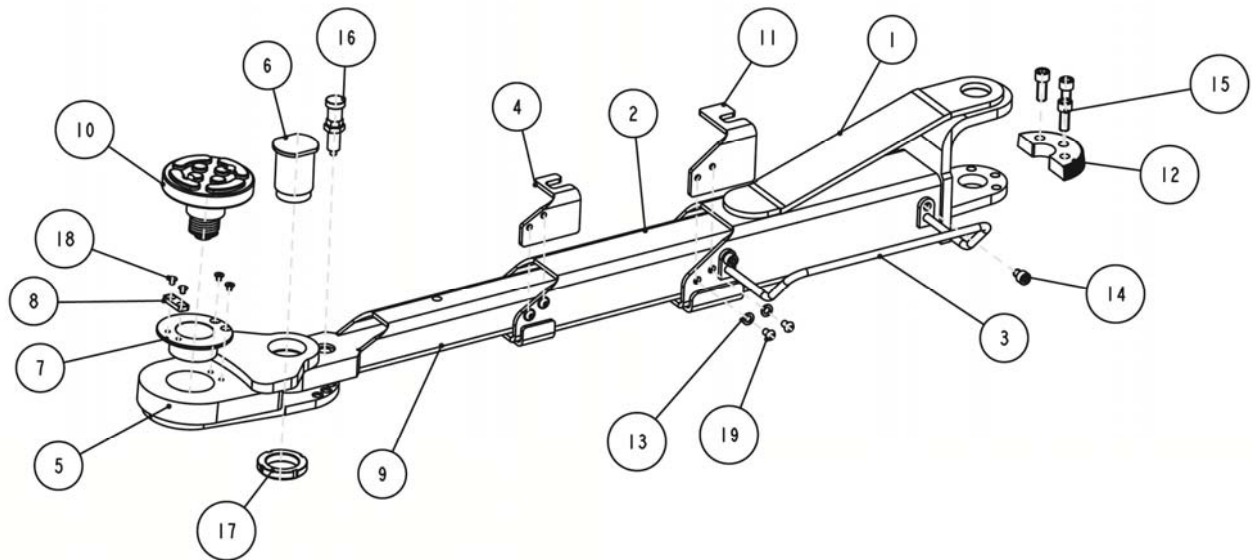
**Optional elbow arm
(653~1065)**

Pos.	Code	Description	Specification	Qty
1	614902035	First stage of the arm	6254E-A27-B1-1	1
2	614902036	Mid arm	6254E-A27-B2-1	1
3	614004012B	Fender	6254E-A27-B4	1
4	410912754	Space padding plate	6254E-A27-B5	1
5	614902034	Support plate	6254E-A36-B1	1
6	410912743	Pin shaft	6254E-A36-B3	1
7	410912746	Orientation sheath	6254E-A36-B4	1
8	410912747	Orientation plate	6254E-A36-B5	1
9	614902037	Retractable arm	6254E-A37-B1	1
10	615004042	Lifting tray assembly	6254E-A7-B4-V0	1
11	410912495	Limitation plate	6254E-A7-B6	1
12	410901074	Semi -teeth block	6254E-A7-B8	1
13	204101005	Flat washer	D8-GB95	4
14	202110018	Hex socket cylinder head screw	M10X12-GB70_1	2
15	202109085	Hex socket cylinder head screw	M12X30-GB70_1	3
16	208107036	Pin	M16X1_5-F02-SF16	1
17	203203005	Nut	M45X1_5-NBD100253	1
18	202111036	Hex socket flat head screw	M6X8-GB70_3	4
19	202110004	Hex socket button head screw	M8X12-GB70_2	4

(775~1250)

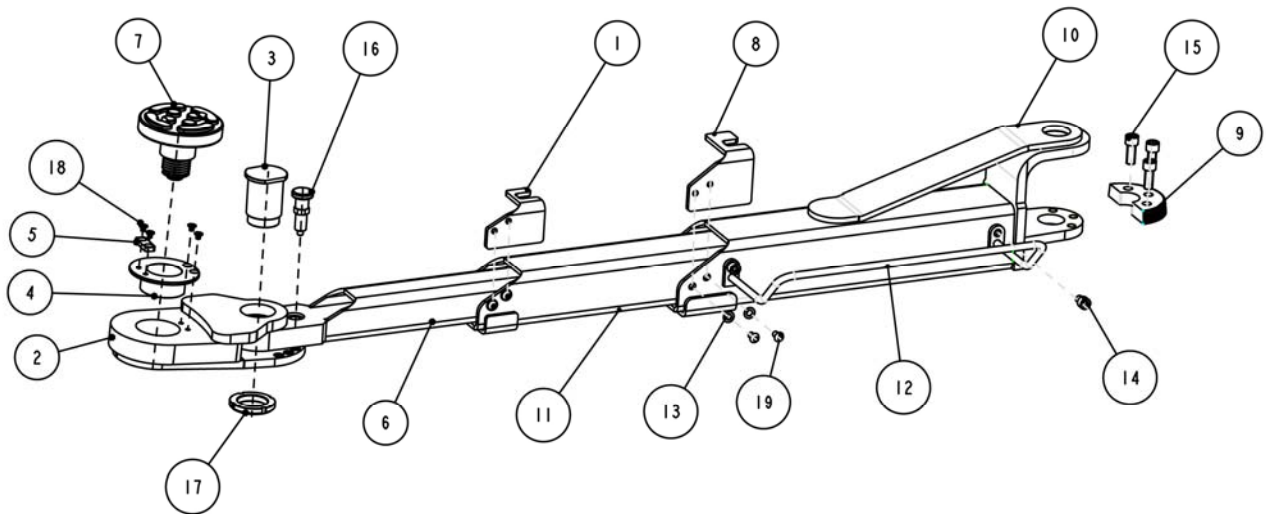

Pos.	Code	Description	Specification	Qty
1	410912754	Space padding plate	6254E-A27-B5	1
2	614902034	Support plate	6254E-A36-B1	1
3	410912743	Pin shaft	6254E-A36-B3	1
4	410912746	Orientation sheath	6254E-A36-B4	1
5	410912747	Orientation plate	6254E-A36-B5	1
6	614902037	Retractable arm	6254E-A37-B1	1
7	615004042	Lifting tray assembly	6254E-A7-B4-V0	1
8	410912495	Limitation plate	6254E-A7-B6	1
9	410901074	Semi-Teeth block	6254E-A7-B8	1
10	614902040	First stage of the arm	6254E-MDN-A10-B1-1	1
11	614902041	Mid arm	6254E-MDN-A10-B2-1	1
12	614004030B	Long fender	6254E-MDN-A10-B4	1
13	204101005	Flat washer	D8-GB95	4
14	202110018	Hex socket cylinder head screw	M10X12-GB70_1	2
15	202109085	Hex socket cylinder head screw	M12X30-GB70_1	3
16	208107036	Pin	M16X1_5-F02-SF16	1
17	203203005	Nut	M45X1_5-NBD100253	1
18	202111036	Hex socket flat head screw	M6X8-GB70_3	4
19	202110004	Hex socket button head screw	M8X12-GB70_2	4

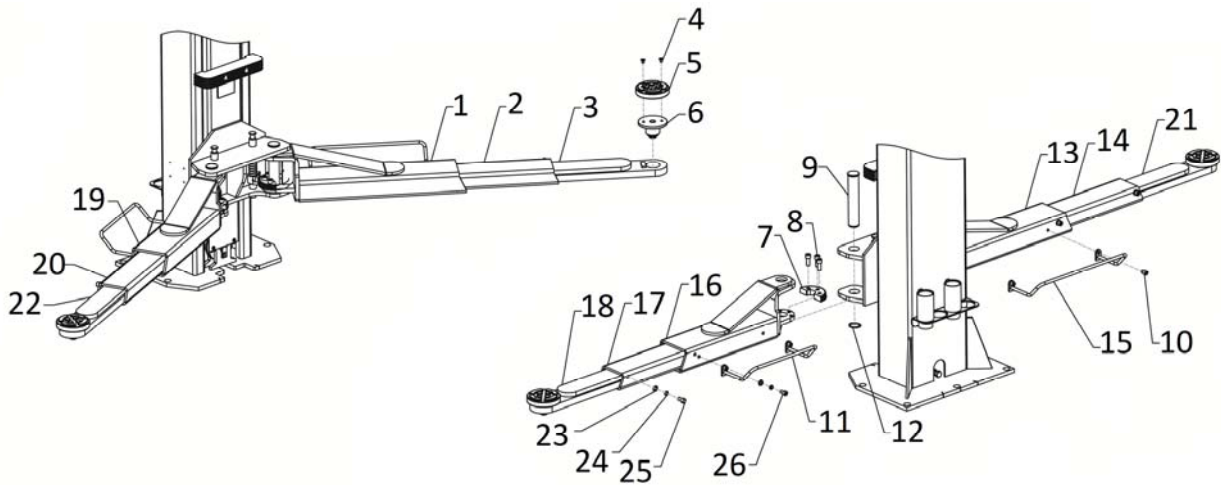
Optional four low-profile 3-stage arms (615-1150, 745-1345)

Pos.	Code	Description	Specification	Qty
1	614901971	Lifting arm of long 3-stage arm (Right)	62CV3-A10-B1	1
2	614901972	Mid arm of long 3-stage arm (Right)	62CV3-A10-B2	1
	614901973B	Retractable arm of the long 3-stage arm (Right)	62CV3-A10-B3-V1	1
4	202111004	Hex socket flat head screw	M8X12-GB70_3	8
5	420040250	Round pad	6254E-A7-B4-C4	4
6	610004547	Low-profile Lifting tray(no contact pad)	6254E-A7-B4-V1	4
4+5+6	610004517	Low-profile Lifting tray assembly	6254E-A7-B4-V2	4
7	410901074	Teeth block (semi-teeth)	6254E-A7-B8	4
8	202109085	Hex socket cylinder head screw	M12X30-GB70_1	12
9	410049031B	Pin shaft	6254E-A12	4
10	202110018	Hex socket cylinder head screw	M10X12-GB70_1	8
11	614004012B	Fender for the short 3-stage arm	6254E-A27-B4	2
12	204301013	Circlip	D38-GB894_1	4
13	614901976	Lifting arm of long 3-stage arm (left)	62CV3-A12-B1	1
14	614901977	Mid arm of the long 3-stage arm (left)	62CV3-A12-B2	1
15	614004030B	Fender for the long 3-stage arm	6254E-MDN-A10-B4	2
16	614901974	Lifting arm of short 3-stage arm (left)	62CV3-A11-B1	1
17	614901975	Mid arm of the short 3-stage arm (left)	62CV3-A11-B2	1
18	614901978B	Retractable arm of the short 3-stage arm (left)	62CV3-A11-B3-V1	1
19	614901968	Lifting arm of short 3-stage arm (Right)	62CV3-A9-B1	1
20	614901969	Mid arm of short 3-stage arm (Right)	62CV3-A9-B2	1
21	614901979B	Retractable arm of the long 3-stage arm (left)	62CV3-A12-B3-V1	1
22	614901970B	Retractable arm of the short 3-stage arm (Right)	62CV3-A9-B3-V1	1
23	204101006	Flat washer	D10-GB95	8
24	204201005	Spring washer	D10-GB93	8
25	202109041	Hex socket cylinder head screw	M10X20-GB70_1	4
26	202109040	Hex socket cylinder head screw	M10X16-GB70_1	4