

Model No. EE-65A-40T

Short platform scissor lift

Low profile

Manual Levelling

Lifting capacity: 4000KG

**Installation, Operation
and Parts Manual**



EAE

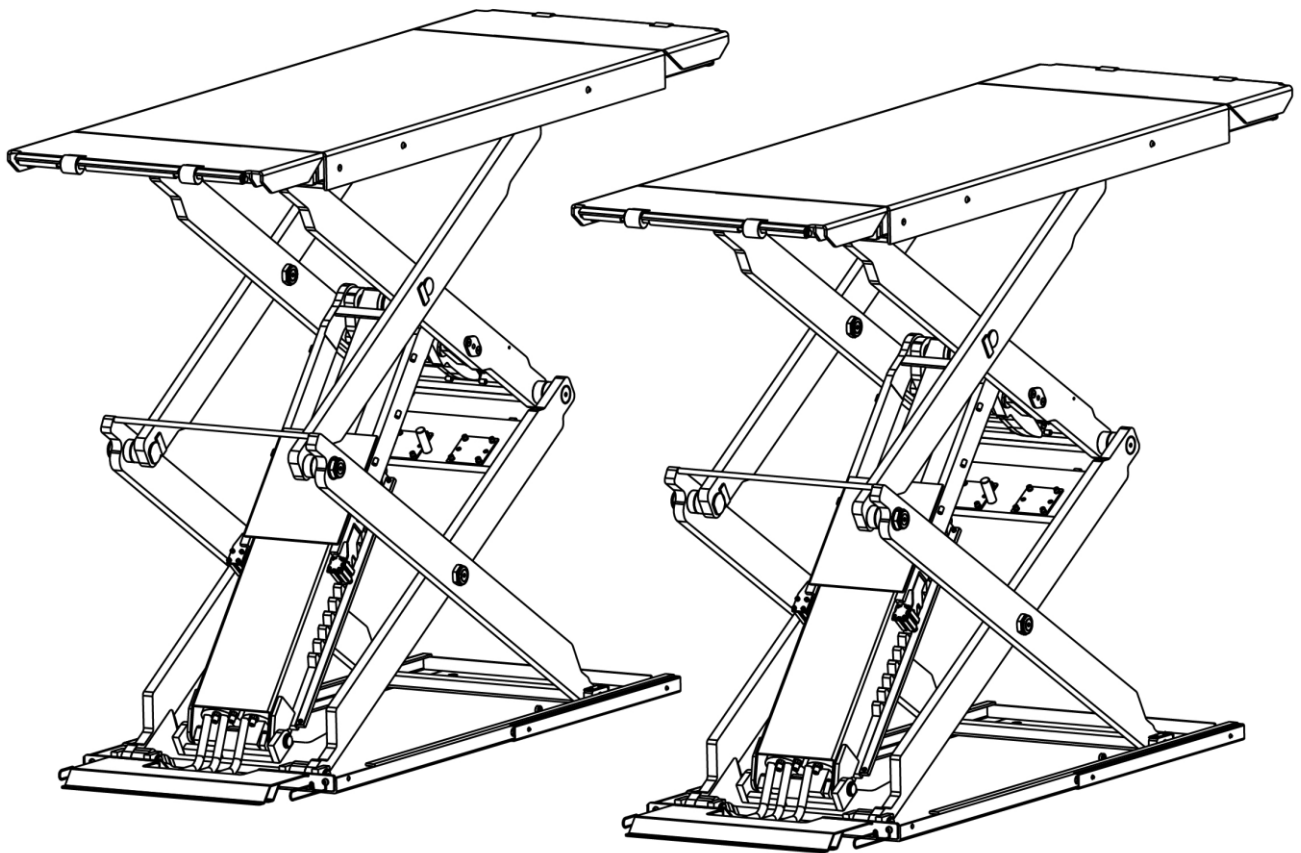

Distributed by

Please read this entire manual carefully and completely before installation or operation of the lift.

22/10/2018

www.eae-ae.com

IMPORTANT NOTES

Before start up, connecting and operating EAE products, it is absolutely essential that the operating instructions/owner's manual and, in particular the safety instructions are studied carefully. By doing so you can eliminate any uncertainties in handling EAE products and thus associated safety risks up front; something which is in the interest of you own safety and will ultimately help avoid damage to the device, When an EAE product is handed over to another person, not only the operating instructions but also the safety instructions and information on its designated use must be handed over to the person.

By using the product you agree the following conditions:

Copy right

The enclosed instructions are the property of EAE or its supplier, and are protected against duplication and reproduction by copyright laws, international agreements, and other domestic legislation. The reproduction or disclosure of instructions or an extract thereof is prohibited and offenders are liable to prosecution; EAE reserves the right or initiates criminal proceedings and asserts claims for damages in the event of infringements.

Warranty

The use of non-approved hardware will result in a modification of our products and thus to the exclusion of any liability or warranty, even if such hardware has been removed again in the interim.

It is not permissible to make any changes to our products and these are not only to be used together with genuine accessories and genuine replacement parts. Otherwise any warranty claims will be invalid.

Liability

The liability of EAE is limit to the amount that the customer has actually paid for this product. This exclusion of liability does not apply to damages caused through willful misconduct or gross negligence on the part of EAE.

All information in this manual is believed to be correct at time of publication.

EAE reserves the right to amend and alter technical data and composition without prior notice.

Please confirm at time of ordering.

IMPORTANT NOTES	2
SAFETY NOTES	4
1.1 Operation of lifting platforms	4
1.2 Checking of the lifting platforms.....	4
1.3 Important safety notices	5
1.4 Warning labels.....	6
1.5 Potential safety risks	7
1.6 Noise level.....	7
PACKING, STORAGE AND TRANSPORTATION	8
2.1 The lift was dismantled into the following 2 parts for transportation	8
2.2 Storage.....	8
2.3 Lifting and handling	8
PRODUCT DESCRIPTIONS	9
3.1 General descriptions	9
3.2 Construction of the lift	9
3.3 Dimensions.....	9
3.4 Safety devices descriptions	10
3.5 Technical data.....	10
INSTALLATION INSTRUCTIONS	11
4.1 Preparations before installation	11
4.2 Installation attentions.....	13
4.3 General Installation Steps.....	14
4.4 Items to be checked after installation.....	17
OPERATION INSTRUCTIONS	18
5.1 Precautions	18
5.2 Operation instructions	18
5.3 Flow chart for operation	18
5.4 Operation instructions	19
TROUBLE SHOOTING	20
MAINTENANCE	21
Annex 1,Electrical schemes and parts list	23
Annex 2, Hydraulic schemes and parts list.....	27
Annex 3, Pneumatic schemes and parts list.....	27
Annex 4, Mechanically exploded drawings and parts list	32

SAFETY NOTES

1.1 Operation of lifting platforms

This lift is specially designed for lifting motor vehicles. Users are not allowed to use it for any other purposes. The applicable national regulations, laws and directives must be observed.

Only users aged 18 or above who have been instructed on how to operate the lifting platform and have proven their ability to do so to the owner are to be entrusted with unsupervised operation of lifting platforms. The task of operating the lifting platforms must be granted in writing.

Before loading a vehicle onto the lifting platform, users should study the original operation instructions and familiarize themselves with the operating procedures in several trial runs.

Lift vehicle within the rated load. Don't attempt to raise vehicles with excessive weight.

1.2 Checking of the lifting platforms

Checks are to be based on the following directives and regulations:

- Basic principles for testing lifting platforms
- The basic health and safety requirements stipulated in the directive 2006/42/EC
- Harmonized European standards
- The applicable accident prevention regulations

The checks are to be organized by the user of the lifting platform. The user is responsible for appointing an expert or qualified person to perform checking. It must be ensure that the person chosen satisfies the requirements.

The user bears special responsibility if employees of the company are appointed as experts or qualified persons.

1.2.1 Scope of checking

Regular checking essentially involves performing a visual inspection and a functional test. This includes checking the condition of the components and equipment, checking that the safety systems are complete and functioning properly and that the inspection log book is completely filled in. The scope of exceptional checking depends on the nature and extent of any structural modification or repair work.

1.2.2 Regular checking

After initial commissioning, lifting platforms are to be checked by a qualified person at intervals of not longer than one year.

A qualified person is somebody with the training and experience required to possess sufficient knowledge of lifting platforms and who is sufficiently familiar with the pertinent national regulations, accident prevention regulations and generally acknowledged rules of engineering to be able to assess the safe operating condition of lifting platforms.

1.2.3 Exceptional checking

Lifting platforms with a lift height of more than 2 meters and lifting platforms intended for use with people standing under the load bearing elements of the load are to be checked by an expert prior or reuse following structural modifications and major repairs to load bearing components.

An expert is somebody with the training and experience required to possess specialist knowledge of lifting platforms and who is sufficiently familiar with the pertinent national work safety regulations, accident prevention regulations and generally acknowledged rules of engineering to be able to check and give an expert option on lifting platforms.

1.3 Important safety notices

1.3.1 Recommend for indoor use only. DO not expose the lift to rain, snow or excessive moisture.

1.3.2 Only use this lift on a surface that is stable and capable of sustaining the load. Do not install the lift on any asphalt surface.

1.3.3 Read and understand all safety warnings before operating the lift.

1.3.4 Do not leave the controls while the lift is still in motion.

1.3.5 Keep hands and feet away from any moving parts. Keep feet clear of the lift when lowering.

1.3.6 Only these properly trained personnel can operate the lift.

1.3.7 Do not wear unfit clothes such as large clothes with flounces, tires, etc., which could be caught by moving parts of the lift.

1.3.8 To prevent evitable incidents, surrounding areas of the lift must be tidy and with nothing unconcerned.

1.3.9 The lift is simply designed to lift the entire body of vehicles, with its maximum weight within the lifting capacity.

1.3.10 Always insure the safety locks are engaged before any attempt to work near or under the vehicle. Never remove safety related components from the lift. Do not use if safety related components are damaged or missing.

1.3.11 Do not rock the vehicle while on the lift or remove any heavy component from vehicle that may cause excessive weight shift.

1.3.12 Check at any time the parts of the lift to ensure the agility of moving parts and the performance of synchronization. Ensure regular maintenance and if anything abnormal occurs, stop using the lift immediately and contact our dealers for help.

1.3.13 Lower the lift to its lowest position and do remember to cut off the power source when service finishes.

1.3.14 Do not modify any parts of the lift without manufacturer's advice.

1.3.15 If the lift is going to be left unused for a long time, users are required to:

a. Disconnect the power;

b. Empty the oil tank;

c. Lubricate the moving parts with hydraulic oil.

WARNING: The warnings, cautions and instructions discussed in this instruction manual cannot cover all possible conditions and situations that may occur. It must be understood by the operator that common sense and caution are factors which cannot be built into this product, but must be supplied by the operator.

1.4 Warning labels

All safety warning labels are clearly depicted on the lift to ensure that the operator is aware of and avoid the dangers of using the lift in an incorrect manner. The labels must be kept clean and they have to be replaced if detached or damaged. Please read carefully the meaning of each label and memories them for future operation.

SAFETY ADVICE

540101636B

 <p>The operation of the lift is permitted by authorised persons only.</p>	<p>The field of motion shall be free of obstructions.</p> 
 <p>Do not try to raise a vehicle exceeds the rated capacity.</p>	<p>Never raise just one end, one corner or one side of vehicle.</p> 
 <p>Observe the load carrying device throughout the motion of the lift.</p>	<p>Make sure vehicle is neither front nor rear heavy and center of balance should be centered over the lift.</p> 
 <p>Make sure that two platforms are of equal height from the floor when safety teeth engaged.</p>	<p>Avoid excessive rocking of vehicle while on lift.</p> 
 <p>Travelling on the load carrying devices is forbidden.</p>	<p>Always keep the lift pit clean and clear of any objects or contaminants.</p> 
 <p>Do not remove, modify or interrupt safety related components or devices.</p>	<p>Carry out maintenance regularly as indicated in the manual.</p> 

1.5 Potential safety risks

1.5.1 Mains voltage



Insulation damage and other faults may result in accessible components being live

Safety measures:

- Only ever use the power cord provided or a tested power cord.
- Replace wires with damaged insulation.
- Do not open the operating unit.

1.5.2 Risk of injury, danger of crushing



In the event of excessive vehicle weight, incorrect mounting of the vehicle or on removing heavy object, there is a risk of the vehicle falling off the lifting platform or tipping up.

Safety measures:

- The lifting platform is only ever to be employed for the intended purpose.
- Carefully study and heed all the information given in Section 1.4.
- Observe the warning notices for operation.

1.6 Noise level

Noise emitted during operating the lift should be less than 70dB. For your health consideration, it is suggested to place a noise detector in your working area.

PACKING, STORAGE AND TRANSPORTATION

Packing, lifting, handling, transporting operations must be performed only by experienced personnel with appropriate knowledge of the lift and after reading this manual.

2.1 The lift was dismantled into the following 2 parts for transportation

Name	Packed by	Dimension(mm)	Weight(kg)	Quantity
Control cabinet	Wooden case	580*520*1010	100	1
Lift platforms	Carton with wooden base	2030*700*410	1030	1

2.2 Storage

The packs must be kept in a covered and protected area in a temperature range of -10°C to $+40^{\circ}\text{C}$. They must not be exposed to direct sunlight, rain or water.

Stacking the packs

We advise against stacking because the packs are not designed for this type of storage. The narrow base, heavy weight and large size of the packs make stacking difficult and potentially dangerous.

If stacking is unavoidable, use all appropriate precautions:

- never stack to more than 2 meters in height.
- never make stacks of single packs. Always stack pairs of packs in a cross pattern so that the base is bigger and the resulting stack is more stable. Once the stack is complete, restrain it using straps, ropes or other suitable methods.

A maximum of two packs can be stacked on lorries, in containers, and in railway wagons, on condition that the packs are strapped together and restrained to stop them falling.

2.3 Lifting and handling

The packs can be lifted and transported only by using lift trucks.

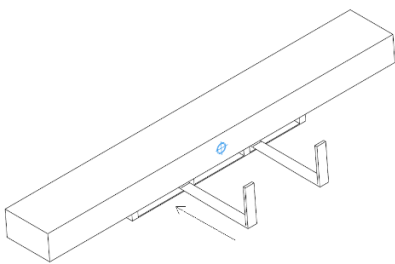

Opening the packs

When the lift is delivered make sure that it has not been damaged during transportation and that all the parts specified on the packing list are present.

Packs must be opened adopting all the precautions required to avoid injury to persons (keep at a safe distance when cutting the straps) or damage to parts of the machine (be careful that no parts are dropped while you are opening the packing)

Take special care with the hydraulic power unit, the control panel and the platform cylinder.

PRODUCT DESCRIPTIONS

3.1 General descriptions

This is chassis supporting lift for road vehicles.

It is of pretty lower profile when at its lowest position. As it is specially designed for surface mounting, users could have it installed with great convenience. Its platform extension design not only can be used as a ramp, but also can serve as an extended part of the platform for much longer vehicles. Besides, designs like, 24V working voltage of control box and limit switch, alarming buzzer, pneumatic safety lock, anti-surge valves, etc. have fully considered your personal security.

3.2 Construction of the lift

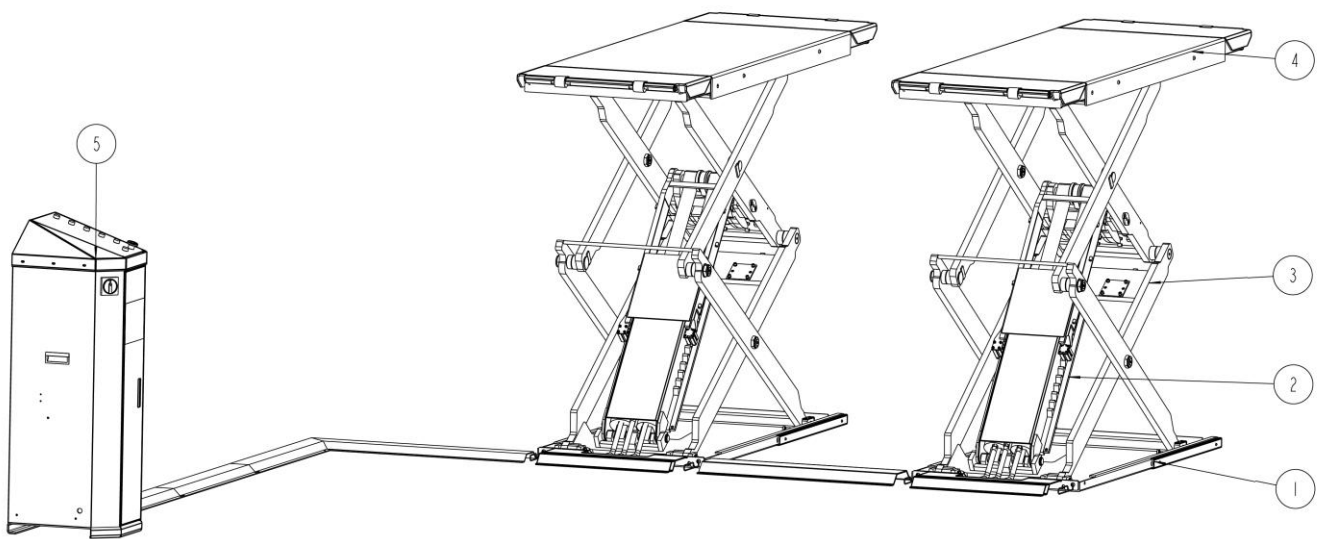

1. Base frame assembly 2. Mechanical locking assembly 3. Support scissor bracket 4. Lifting platform 5. Control unit

3.3 Dimensions

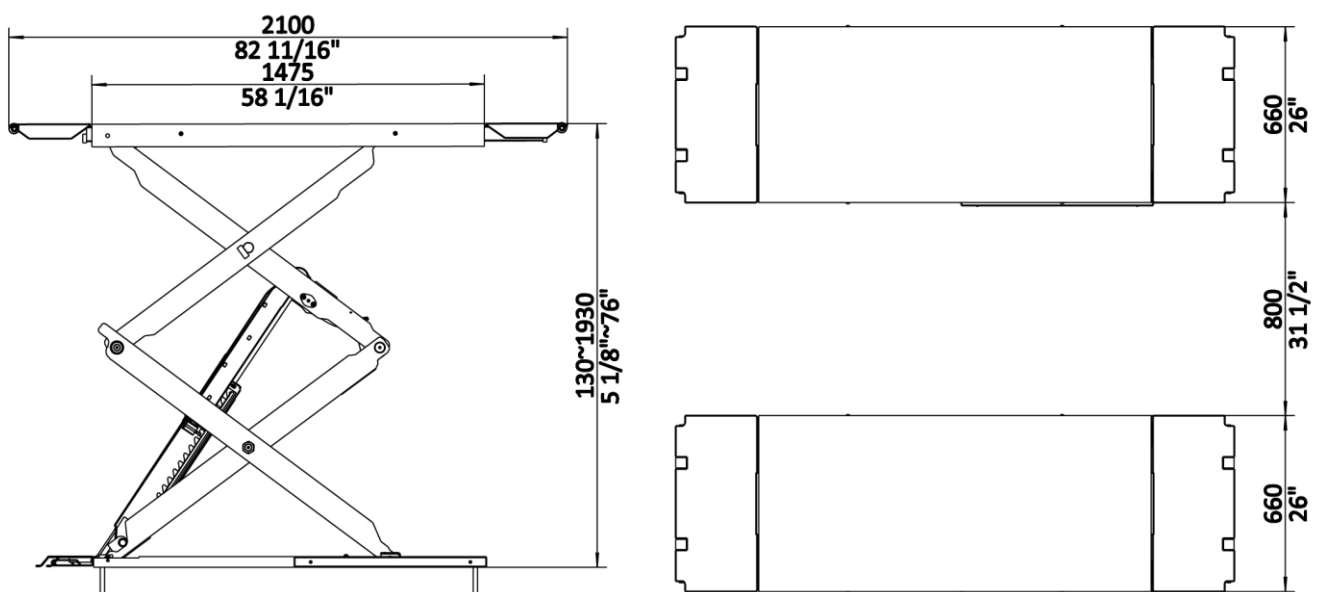

3.4 Safety devices descriptions

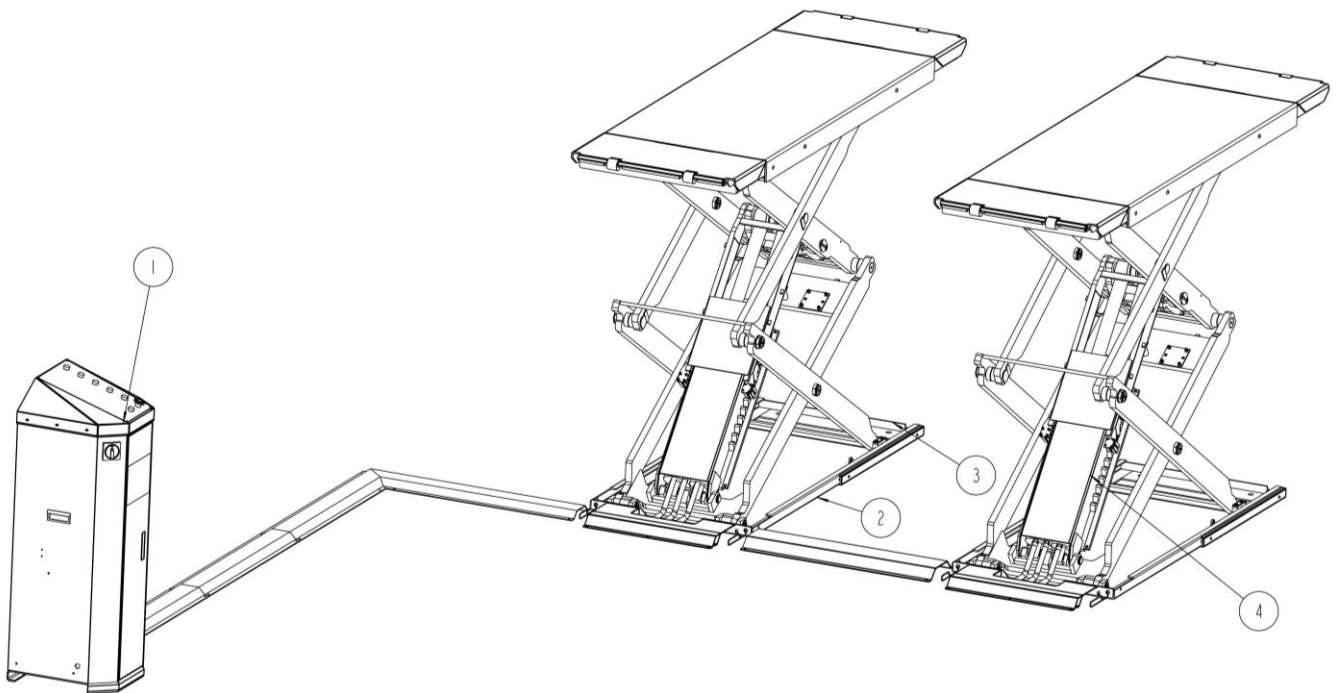

POS.	Safety device	Function
1	24V operation voltage	Safety voltage for operators.
2	Max height limit switch	Ensure the lifting platform stop rising at normal maximum height above the ground.
3	Safety lowering height limit switch	The lifting platforms stop lowering at a safety height above the ground. Push DOWN II button to continue the lowering movement, which accompanies with alarming buzz warning service persons being away from the moving parts..
4	Mechanical lock	Protect the lifting platform from descending dangerously in case of hydraulic failure.

3.5 Technical data

Rated load capacity	4000kg
Full rise time with load	≤60s
Full lowering time with load	≤30s
Hydraulic pressure	28MPa
Pneumatic pressure	6-8 bar
Oil Volume	10L

INSTALLATION INSTRUCTIONS

4.1 Preparations before installation

4.1.1 Space requirements.

Refer to 3.3 for the dimensions of the lift. There must also be a clearance of at least 1 meter between the lifting platform and fixed elements (e.g. wall) in all lifting positions. There must be sufficient space at the ends of the lifting platform for driving vehicles on and off.

To stop vehicles colliding with the ceiling, it is advisable to fit an overhead light barrier in low ceiling buildings.

4.1.2 Foundations and connections

The user must have the following work performed before erecting the lift.

- Construction of the foundation following consultation with the manufacturer's customer service or an authorized service agent. Routing of the wiring to the installation location. **The user must provide fuse protection for the connection. *Electrical system connection must be done by licensed technicians.* Requirements for power supply cable of the installation site: at least 2.5mm² wire core for 3Ph power and 4.0mm² wire core for 1Ph power.**
- Refer also to the corresponding information on the name plate and in the operation instructions. **Before doing electrical connection, make sure the lift is electrically adapt to the local power supply.**
- Routing of the compressed air connection to the installation location.

4.1.3 Foundations preparations

Indoor installation only.

There must also be a clearance of at least 1 meter between the lifting platform and fixed elements (e.g. wall) in all lifting positions. There must be sufficient space for driving vehicles on and off.

C25/30 concrete base with a minimum thickness of 150mm.

Surface: Horizontal and even (Gradients max. 0.5 %)

Newly built concrete ground must be older than 20days.

In mm.

Surface mounting

If the minimum chassis-ground clearance for your serviced cars is less than 200mm, it is suggest to install an additional set of ramps to satisfy surface mounting. Otherwise, it could be hard to lift cars with chassis-ground clearance being less than 200mm.

The area enclosed by the dash line (2500mm*2500mm) shall have a minimum thickness of 150mm.

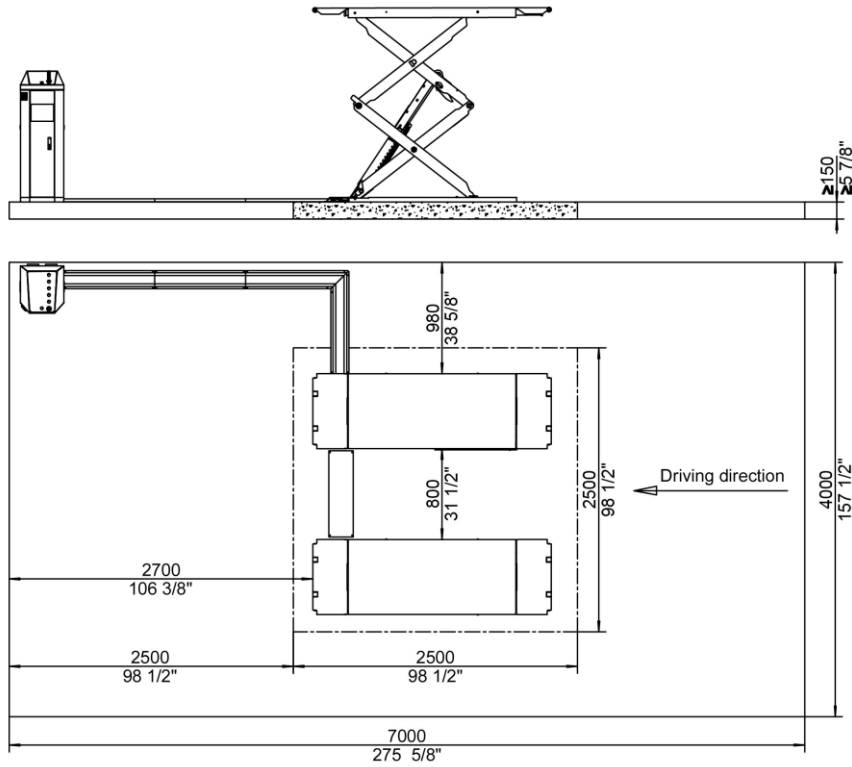

Recessed mounting

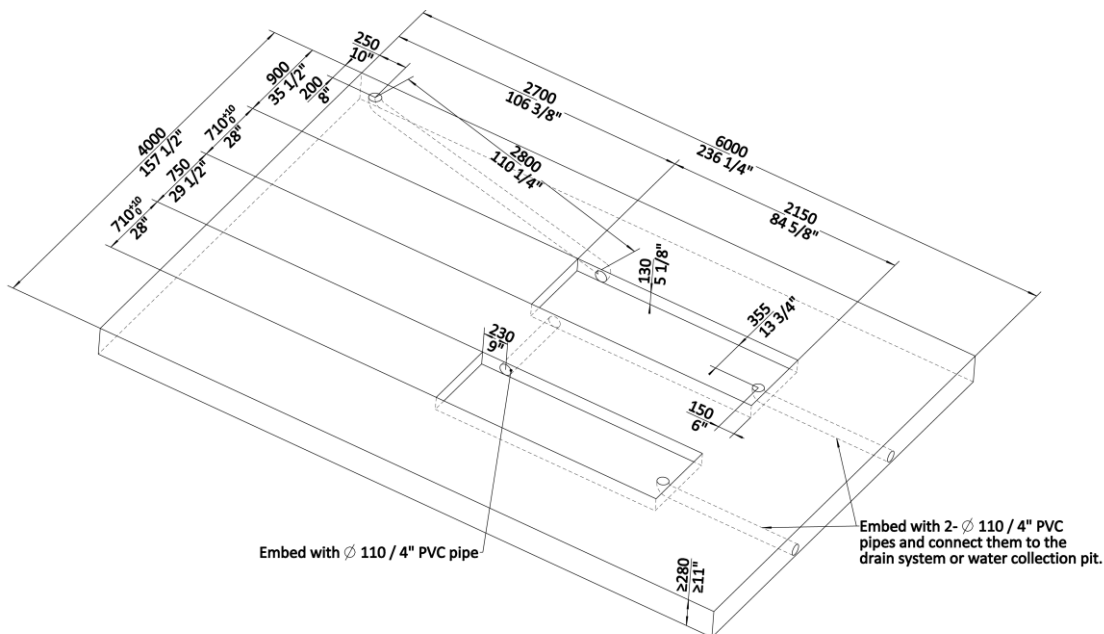

4.1.4 Tools and equipment needed for installation

Tool name	Specification	Qty
Electrical drill	With D16 and D18 drill bit.	1
Open spanner	D17-19mm	2
Adjustable spanner	bigger than D30mm	1
Cross socket screw driver	PH2	1
Quick spanner handle adapter/ Ratchet		1
Socket spanner	D24mm	1
Levelling device	1mm accuracy	1
Hammer	10 pounds	1
Truck lift	Capacity, 1000kg	1
Lifting string	Capacity, 1000kg	2

4.1.5 Checking parts

Unfold the package and check if any parts missed as per the following list. Do not hesitate to contact us in case any parts missed, but if you do not contact us and insist installing upon the lack of some parts, we as well as our dealers will not bear any responsibility for this and will charge for any parts subsequently demanded by the buyer.

Control cabinet package			
No.	Name	Specification	Qty
1	Control unit		1
2	Rubber pad	38mm	4
3	Expansion bolt	M16*120	8
4	Pneumatic hose	D=8	2m
5	Manual	A4	1
7	Key		1
8	Oil tanks label		1
Platform package			
No.	Name	Specification	Qty
1	65A.40T main platform		1
2	65A.40T secondary platform		1
3	Oil hose covers		5

4.2 Installation attentions

4.2.1 Joints of oil hose and wiring must be firmly connected in order to avoid leakage of oil hose and loose of electrical wires.

4.2.2 All bolts should be firmly screwed up.

4.2.3 Do not place any vehicle on the lift in the case of trial running.

4.3 General Installation Steps

Step 1: Dismantle the package of the lifting platforms.

Remove the carton and packing films wrapped on the platform.

Attention 1: Take off oil hose protectors when cut off the packing strips.

Attention 2: Avoid scratching the painting surface and hoses.

Step 2: Place the lifting platform at expected installation site.

Raise the upper platform by using a forklift and 2 lifting strings until the mechanical lock is engaged. And then hoist the platform to the expected installation site. Dismantle the bolts that fix the lower platform and its wooden package and hoist it to the installation site in the same way as the upper platform.

Attention 1: Before hoisting, make sure the hoses and wires are well protected against damage.

Attention 2: It is necessary to hold the platform during the hoisting process. Irrelevant person is not allowed in installation area.

Step 3: Open the package of the control cabinet and take out accessories in it.

Step 4: Connect oil hoses as per Annex 2.

Screw torque for connector is 60Nm.

Firstly, connect the oil hoses between the two platforms. There are 3 oil hoses together.

And then, connect the 3 oil hoses from the main platform with the tie-ins remained on the hydraulic block in the control cabinet. Oil hoses go into the cabinet through the holes remained at the bottom of the cabinet.

Attention: Connect as per the marks on the hoses and do not contaminate the hydraulic components during the connection.

Step 5: Connect the electrical system.

Requirements for power supply cable of the installation site: at least 2.5mm² wire core for 3Ph power and 4.0mm² wire core for 1Ph power.

Refer to Annex 1 when fix the electrical system.

Connect the wire connectors for rising and lowering limit switches.

Connect the power supplier cable to external electricity supply.

(For three phase power supply, if the lift doesn't raise and the motor may turn in the wrong direction, in such event, interchange wires U, V in the control cabinet).

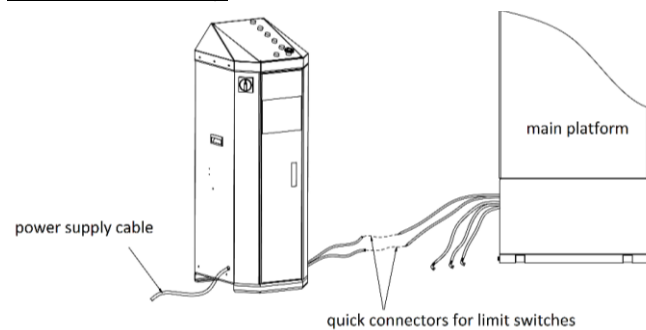

Step 6: Connect the pneumatic release system.

Screw torque for connector is 20Nm.

Connect air hoses as per the following fig.

External compressed shall be prepared by the end user before installation. Pneumatic pressure: 6 -8bar.

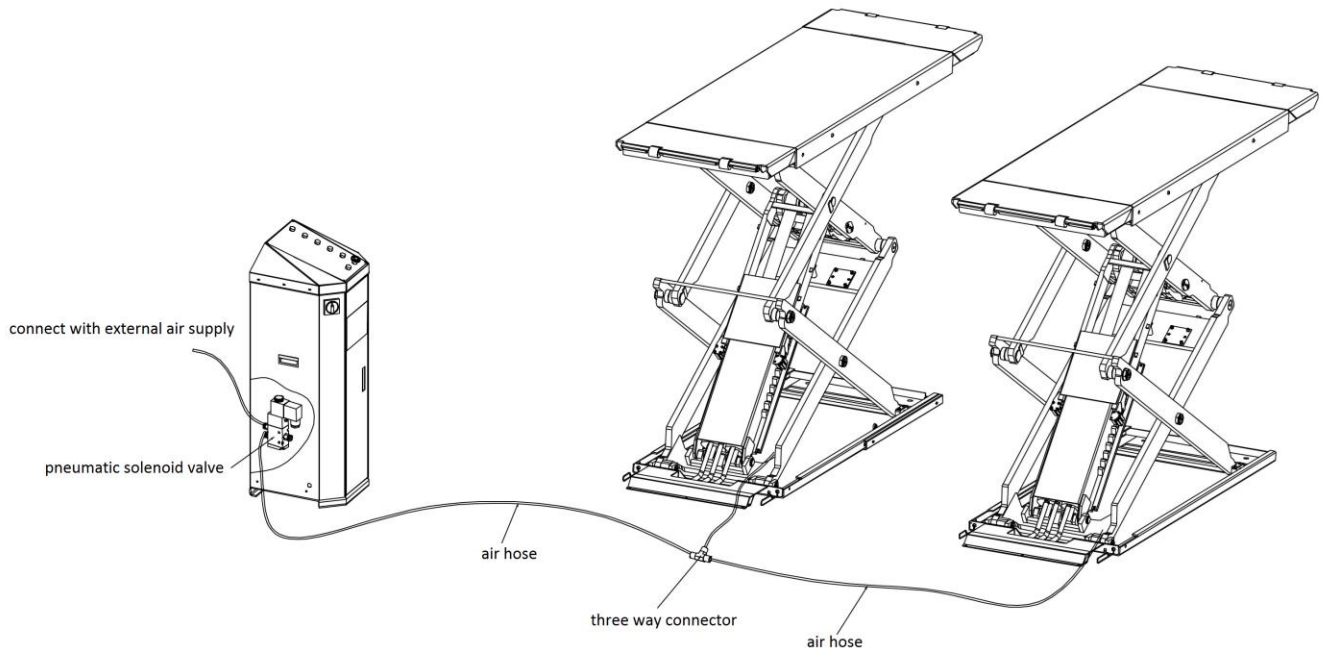

Step 7: Fill with hydraulic oil.

CLEAN AND FRESH OIL ONLY. DON'T FILL THE TANK COMPLETELY FULL.

Lift must be fully lowered before changing or adding hydraulic oil

Pour 10 liters of anti-abrasion hydraulic oil into the oil tank. The level of oil shall reach the tippets volume mark of the tank.

Add more oil after running the lift for several cycles until the lift can rise to the maximum lifting height.

Note: It is suggested to use HM NO.46 hydraulic oil. Use NO.32 hydraulic oil when temperature is below 10 degree Celsius.

Change the oil 6 months after initial use and change once per year thereafter.

Step 8: Levelling

Refer to 5.2 and 5.4 operation instructions before levelling operation.

Check the connection of the hydraulic and electrical system before levelling operation. Ensure the oil hoses are correctly connected.

Otherwise, oil cylinders may not work synchronously or could be damaged.

Review operation instructions and get familiar with lift controls by running the lift through a few cycles before levelling operation. In addition, operators need to know clear which levelling valve controls which platform. This could be judged by the way that the oil hose was connected or by trial raising or lowering.

Open one of the levelling valves and push the UP button to supplement oil to the oil hose connected. Turn off the valve to stop adding oil.

In normal working condition, both levelling valves shall be turned off. In the case both valves are open, two platforms of the lift can still rise but will not move upwards synchronously.

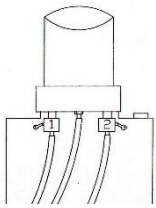
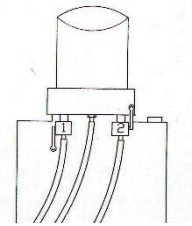
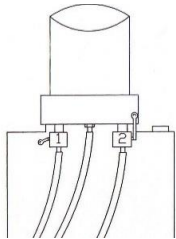
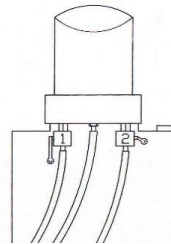
A. Both valves open

B. Both valves closed: Normal working

C.

D.
One valve open, the other closed: levelling condition

A.1. Turn on both levelling valves and push the UP button to have both platforms raised to the highest positions. Repeat this step for two or three times. (Take care that this step could be time consuming, because there's air in the cylinders and no load on the platforms.)

A.2. Turn off both levelling valves as per drawing B. Push the UP button to see if both platforms rise synchronously. (Normally, till now the platforms may not rise synchronously.)

A.3. If not work synchronously, one platform may rise faster than the other. Users should first judge which leveling valve controls which platform and then turn on the valve that controls the slower-rising platform to supplement oil into its oil hose. Push the UP button to make both platforms rise to the same height. (The other valve here must be closed.)

A.4. Turn off both levelling valves. Push DOWN I button to have both platforms lowered to the lowest position.

A.5. In case they do not lower synchronously, turn on the valve that controls the slower-lowering platform and push DOWN I button to have them lowered to the lowest position and then turn off the levelling valve. If the lift is equipped with a height limit switch, push DOWN II button when platforms stop lowering at a safety height from the ground.

A.6. After both levelling valves having been turned off, push the UP button to check if both platforms rise synchronously.

A.7. Repeat doing step A5 and step A 6 until synchronization achieved.

Step 9: Fix base frames with expansion bolts.

Screw torque: 60 -80Nm

1. Adjust the distance between the two lifting platforms and mark the points for each anchoring bolt.
2. Drill anchor holes with an electrical drill. Make sure to drill vertically.
3. Remove thoroughly the debris and dust in holes and hammer in and secure with expansion bolts.

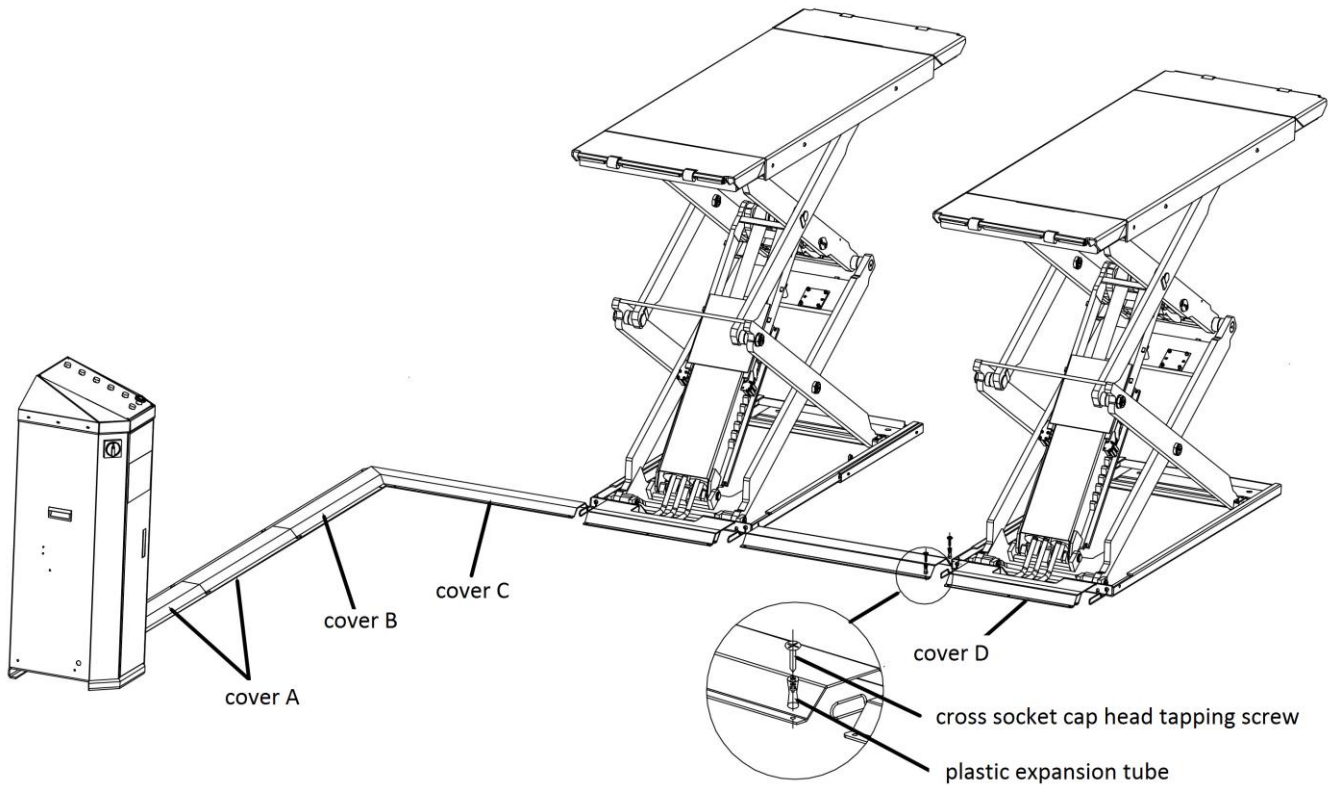
Step 10: Fix oil hose protection covers.

4.4 Items to be checked after installation.

S/N	Check items	YES	NO
1	Screw torque of expansion bolts : 60-80Nm;		
2	Rising speed $\geq 20\text{mm/s}$;		
3	Noise with rated load $\leq 75\text{dB}$;		
4	Grounding resistance: not bigger than 4Ω ;		
5	Height difference of the two platform $\leq 5\text{mm}$;		
6	Mechanical locks are robust and synchronized when running with rated load ;		
7	If the control button works as "hold to run"?		
8	If limit switches work well?		
9	If grounding wire is connected?		
10	If the lift rises and lowers smoothly?		
11	If there is no abnormal noise during running with rated load?		
12	If there is no oil leakage when running with rated load?		
13	If there is no air leakage when running with rated load?		
14	If expansion bolts, nuts or circlips are well secured?		
15	If max lifting height is 1930mm?		
16	If safety advices, name plate and logos are clear?		

OPERATION INSTRUCTIONS

5.1 Precautions

- 5.1.1 Check all connections of oil hose. Only when there is no leakage, the lift can start work.
- 5.1.2 The lift, if its safety device malfunctions, shall not be used.
- 5.1.3 It shall not lift or lower an automobile if its center of gravity is not positioned midway of the runways.
- 5.1.4 Operators and other personnel concerned should stand in a safety area during lifting and lowering process.
- 5.1.5 When runways being raised to the desired height, switch off the power and lock the button with a padlock to prevent any wrong operation done by unconcerned people.
- 5.1.6 Make sure the safety lock of the lift is engaged before start working under the vehicle and no people under the vehicle during lifting and lowering process.

5.2 Control panel descriptions

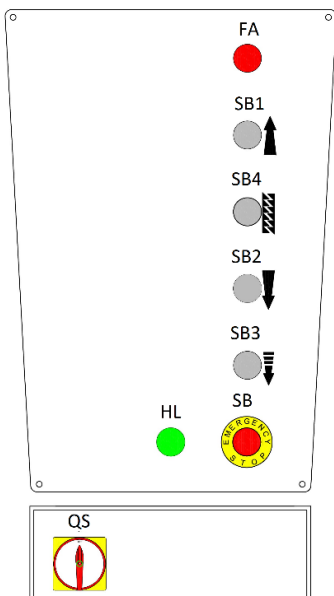

Pos.	Name	Function
FA	Alarm buzzer	Safety warning
SB1	UP button	Control the rising movement
SB2	DOWN I button	Control the lowering movement
SB3	DOWN II button	Control the lowering movement
SB4	Safety lock button	Engage the mechanical safety lock
SB	Emergency stop	Disconnect operation power in emergency case
HL	Power indicator	Show if electricity is connected
QS	Power switch	Control main power

5.3 Flow chart for operation

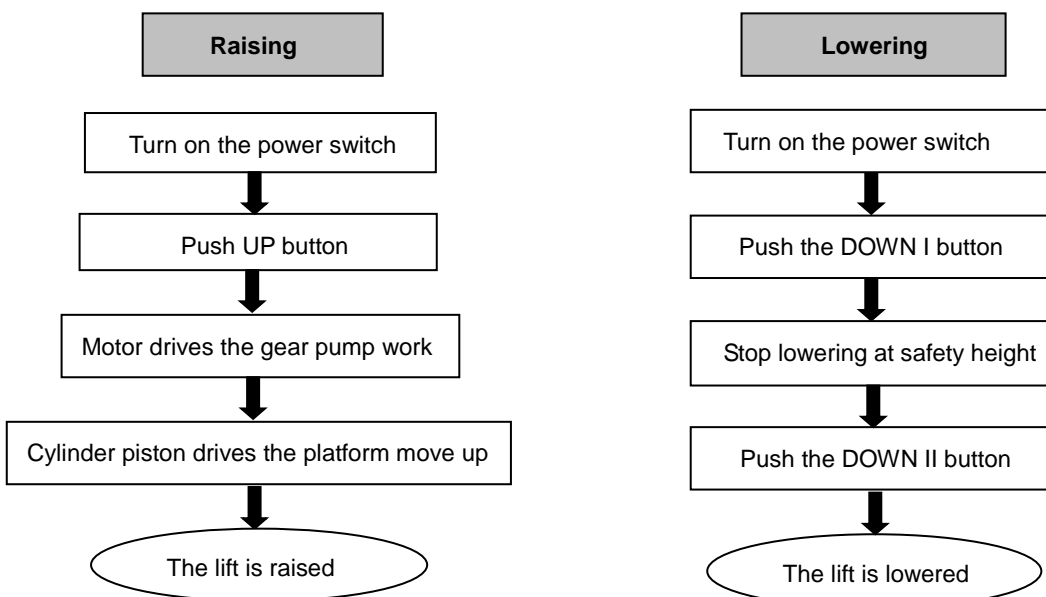

5.4 Operation instructions

To avoid personal injury and/or property damage, permit only trained personnel to operate the lift.

After reviewing these instructions, get familiar with lift controls by running the lift through a few cycles before loading vehicle on lift. Always lift the vehicle using all four adapters. Never raise just one end, one corner or one side of vehicle.

The lift must be only used in a static position for lifting and lowering vehicles.

Raise the lift

Make sure vehicle is neither front nor rear heavy and center of balance should be midway between adapters and centered over the lift.

1. Make sure that you have read and understood the operation manual before operation.
2. Load vehicle on lift carefully. Position the lift adapters to contact at the vehicle manufacturer's recommended lift points.
3. Push the UP button to raise lift until adapters contact vehicle.
4. Check adapters for secure contact with vehicle. Raise lift to expected working height.

Lower the lift

When lowering the lift pay careful attention that all personnel and objects are kept clear.

1. Push the DOWN I button to lower the lifting platform. It will stop lowering at safety height.
2. Push DOWN II button to continue lowering the platforms which accompanies with safety alarming buzz.
3. After the lifting platform is fully lowered, remove rubber pads and other tools to provide an unobstructed exit for moving vehicle from the lift area.
4. Drive the vehicle away.

TROUBLE SHOOTING

ATTENTION: If the trouble could not be fixed by yourself, please do not hesitate to contact us for help.

We will offer our service at the earliest time we can.

Troubles could be judged and solved much faster when more details or pictures could be provided.

TROUBLES	CAUSES	SOLUTION
Motor does not run and will not rise	Loose wire connection	Check and make a good connection.
	Blown motor.	Replace it.
	Damaged limit switch or its wire connection is loose.	Adjust or replace the limit switch.
Motor runs but will not raise	The motor run reversely.	Check the wire connection.
	Overflow valve is not well screwed up or jammed.	Clean or make adjustment
	Damaged gear pump.	Replace it.
	Too low oil level.	Add oil.
	The hose connection is loose.	Tighten it.
	The motor run reversely.	Check the wire connection.
Platforms go down slowly after being raised	The oil hose leaks.	Check or replace it.
	Untightened oil cylinder.	Replace the seal.
	The single way valve leaks.	Clean or replace it.
	The overflow valve leaks.	Clean or replace it.
	Unloading valve leaks.	Check and adjust the tightness.
Rising too slow	Jammed oil filter	Clean or replace it.
	Too low oil level.	Add oil.
	The overflow valve is not adjusted to the right position.	Make adjustment.
	Too hot hydraulic oil (above 45°) .	Change the oil.
	Abraded seal of the cylinder	Replace the seal.
Lowering too slow	Jammed throttle valve	Clean or replace.
	Dirty hydraulic oil	Change the oil.
	Jammed anti-surge valve	Clean it.
	Jammed oil hose	Replace it.

MAINTENANCE

Easy and low cost routine maintenance can ensure the lift work normally and safely. Following are requirements for routine maintenance. You may decide the frequency of routine maintenance by consulting your lift's actual working conditions.

GREASE: No.1 lithium base grease.

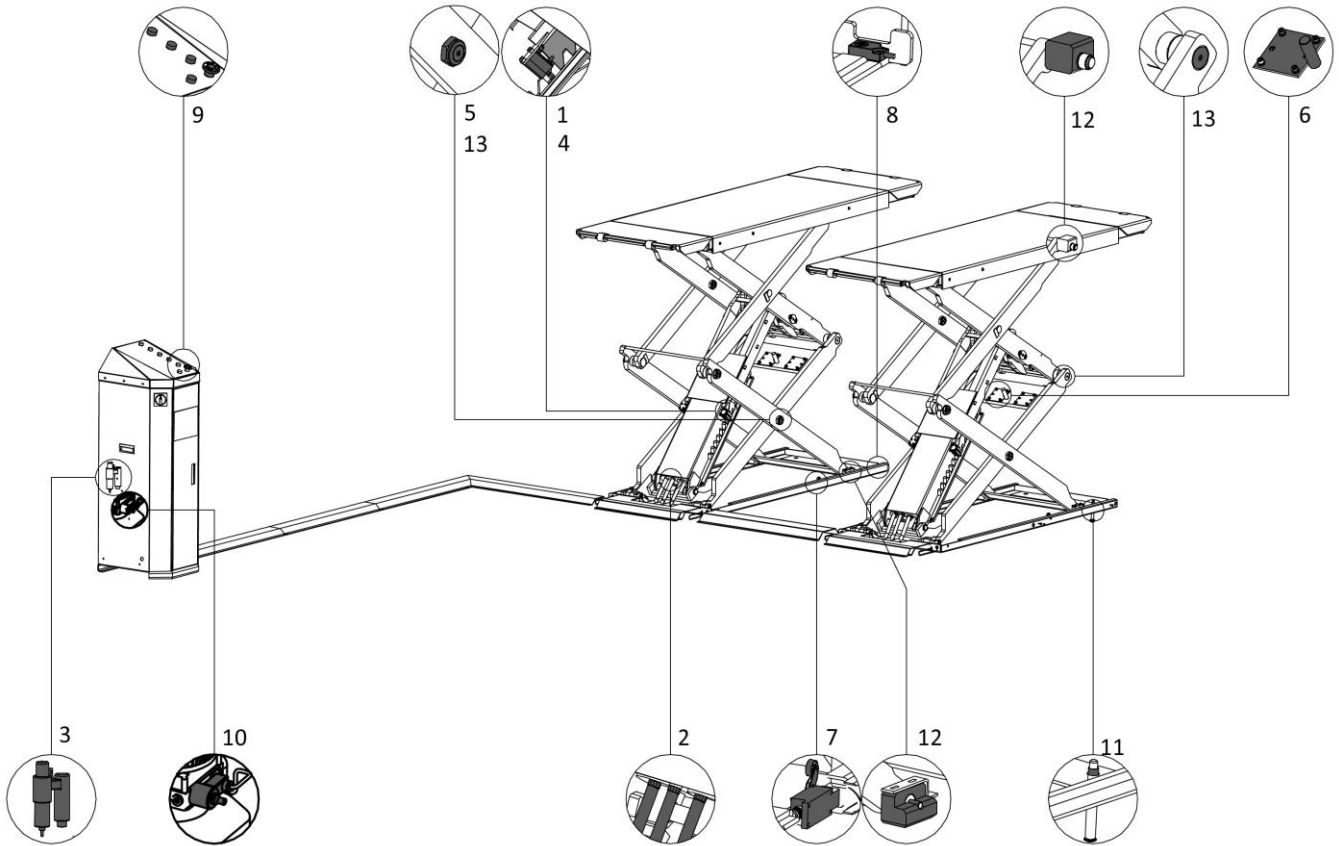

POS.	Components	Methods	Period
1	Mechanical safety catch	Check if both mechanical catches can engage and disengage effectively by pushing control buttons.	Every day
2	Cylinders and oil hose connectors	Inspect to ensure no leakage before using the lift.	Every day
3	Pneumatic filter	Listen and inspect if it leaks or not. Inspect and ensure the water level is below its max limit mark and the oil level is above the minimum limit mark.	Every day
4	Pneumatic hoses and connectors	Inspect to ensure no leakage before using the lift.	Every day
5	Self-locking nut	Check with torque spanner. The torque is no less than 480N.m.	Every day
6	The padding plate and its support rod for initial start plate	Inspect and add grease when necessary.	Every day

POS.	Components	Methods	Period
7	Max height limit switch	Push the UP button and inspect and ensure the lifting platform stops rising at maximum lifting height.	Every day
8	Safety lowering limit switch	Push the DOWN I button. Inspect and ensure the lifting platform stops lowering at safety height and then push DOWN II button to have the platform fully lowered.	Every day
9	Control buttons	Check if control buttons work as "hold- to -run " and check if they work as the function indicated.	Every day
10	Solenoid unloading valve	Inspect if the valve leaks or not. Clean or change the valve if it leaks.	Every day
	Lifting platform	Check and adjust the synchronization of lifting platforms. Ensure both platforms ascend and descend synchronously.	Every day
11	Expansion bolts	Check with torque spanner. 60-80Nm.	Every 3 months
12	Upside and downside sliders	Add grease to ensure smooth running.	Every 3 months
13	Joint shafts	Add grease into the oil cups.	Every 3 months
	Whole Lift	Running the lift for several cycles with and without rated load. The lift can run steadily and smoothly with no abnormal noise.	Every 3 months
	Hydraulic oil	Change the oil 6 months after initial use and once per year thereafter. Inspect and change the oil if it becomes black or there is dirt in the oil tank.	Every year

If users stick to the above maintenance requirements, the lift will always keep a good working condition and its service life could be extended.

Annex 1, Electrical schemes and parts list

(Note: For the specific requirements on voltage, the actual voltage of your lift may differ with the following diagram)

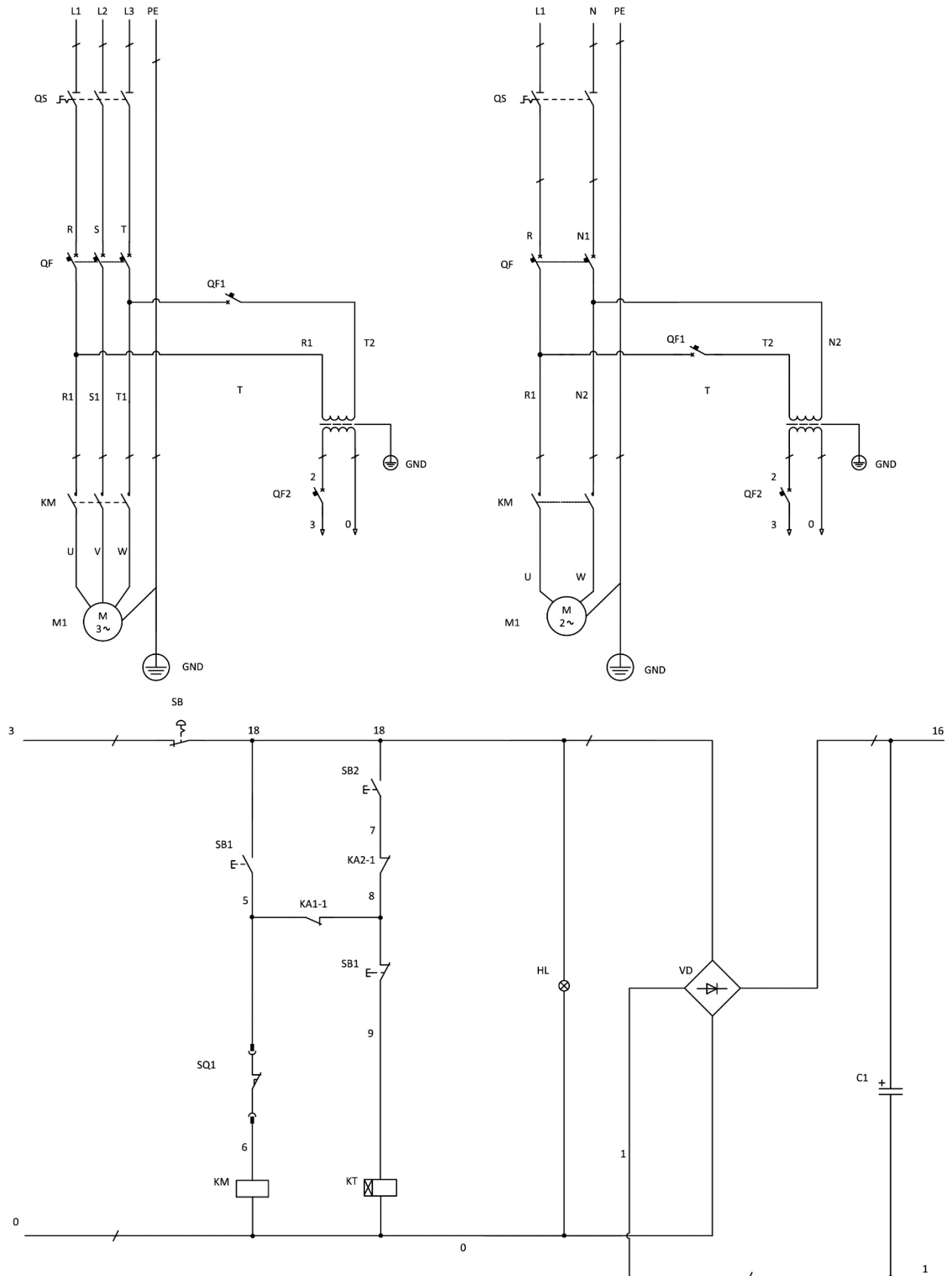

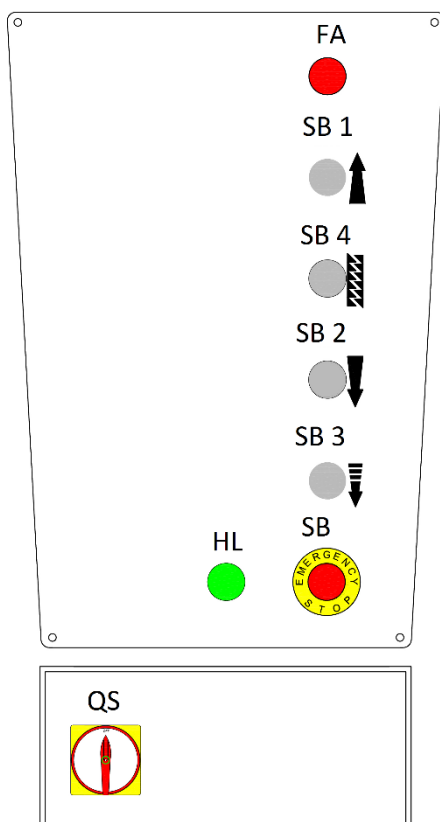
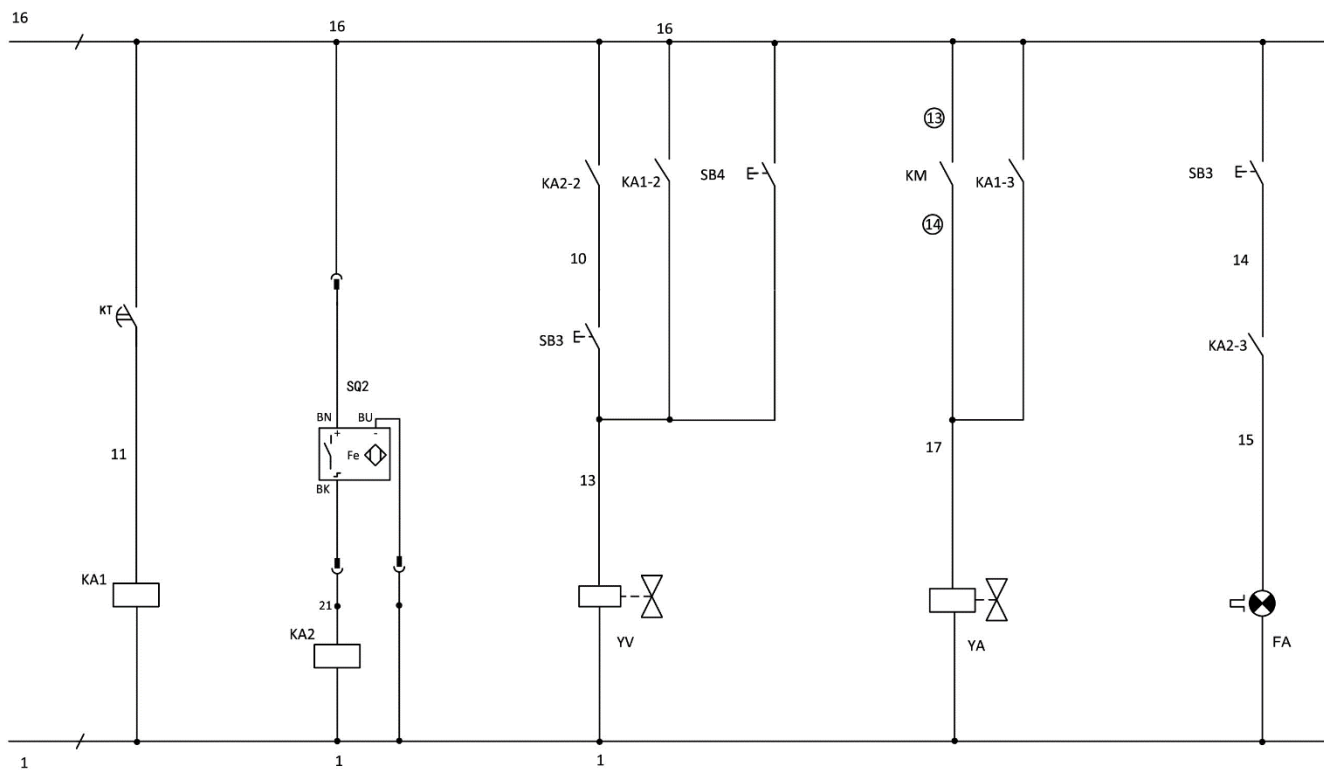

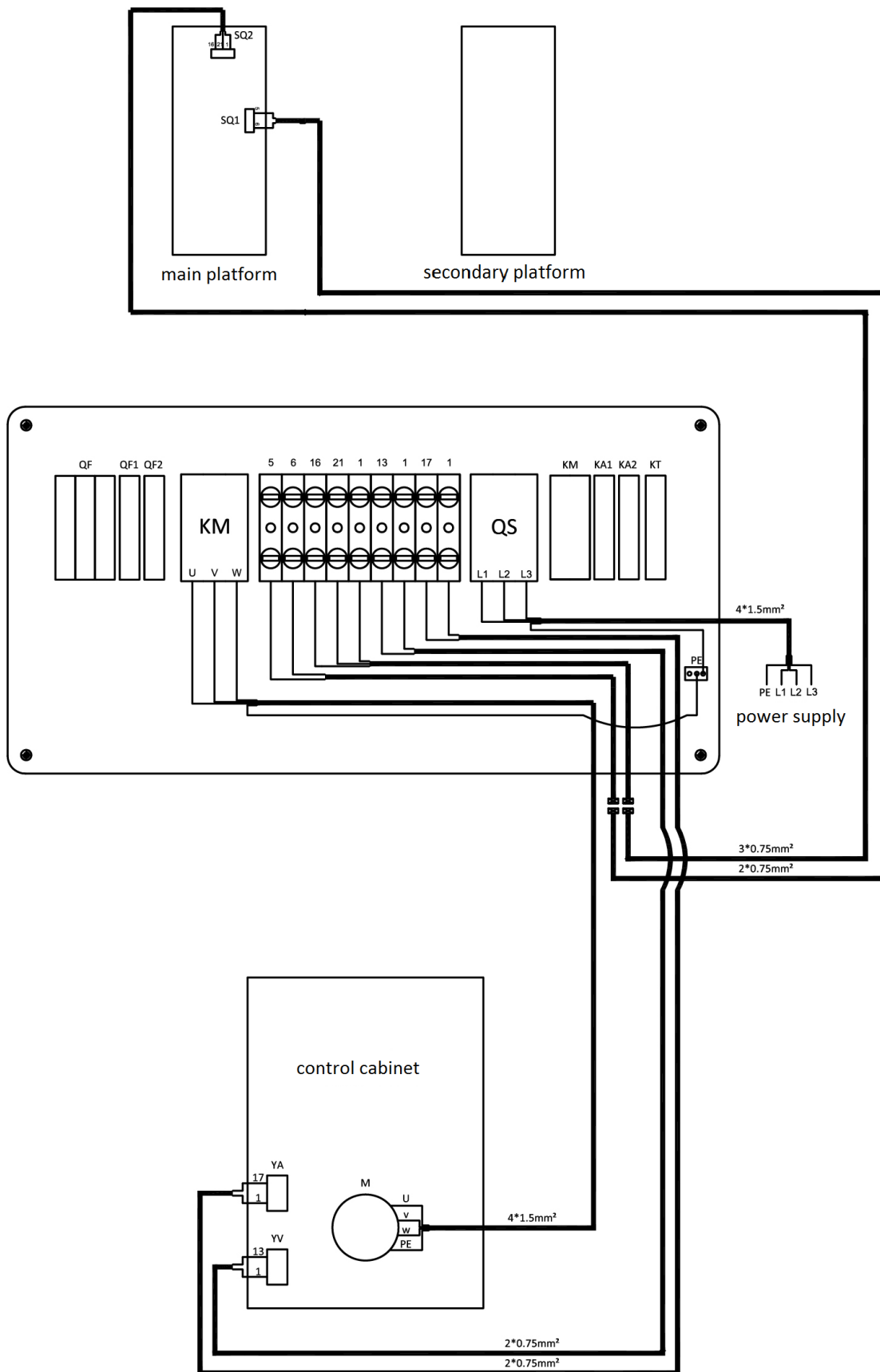

Pos.	CODE	Description	Qty	REMARK
T	320104003	Transformer	1	220V230V240V
	320104004	Transformer	1	380V400V415V
	320102005	Transformer	1	400-230V
M		Motor	1	
SQ2	320306010	Proximity sensor	1	
SQ1	320301009	Limit switch	1	
QS	320304001	Power switch	1	
SB1, SB2,SB4	320401041	Button	3	
SB3	320401038	Button	1	
SB	320402002	Emergency stop	1	
	320503002	Ground terminals	1	
	320505006	Wire terminals	9	
KA1,KA2	320601001	Relay	2	
	320601011	Relay holder	2	
	320601018	Relay feet fixer	4	
KT	320602009	Integrated time relay	1	
QF	320802001	Circuit breaker	1	(1Ph)
	320801001	Circuit breaker	1	(3Ph)
	320801003	Circuit breaker	1	(Dual)
QF1	320803001	Circuit breaker	1	
QF2	320803003	Circuit breaker	1	
KM	320901011	AC contactor	1	(1Ph/Dual)
	320901001	AC contactor	1	(3Ph)
C	321001004	Capacitor	1	
VD	321002001	Bridge rectifier	1	
HL	321201001	Power indicator	1	
FA	321202001	Alarm buzzer	1	
YA	310401001	Pneumatic solenoid valve	1	
YV	330308006	Solenoid unloading valve	1	

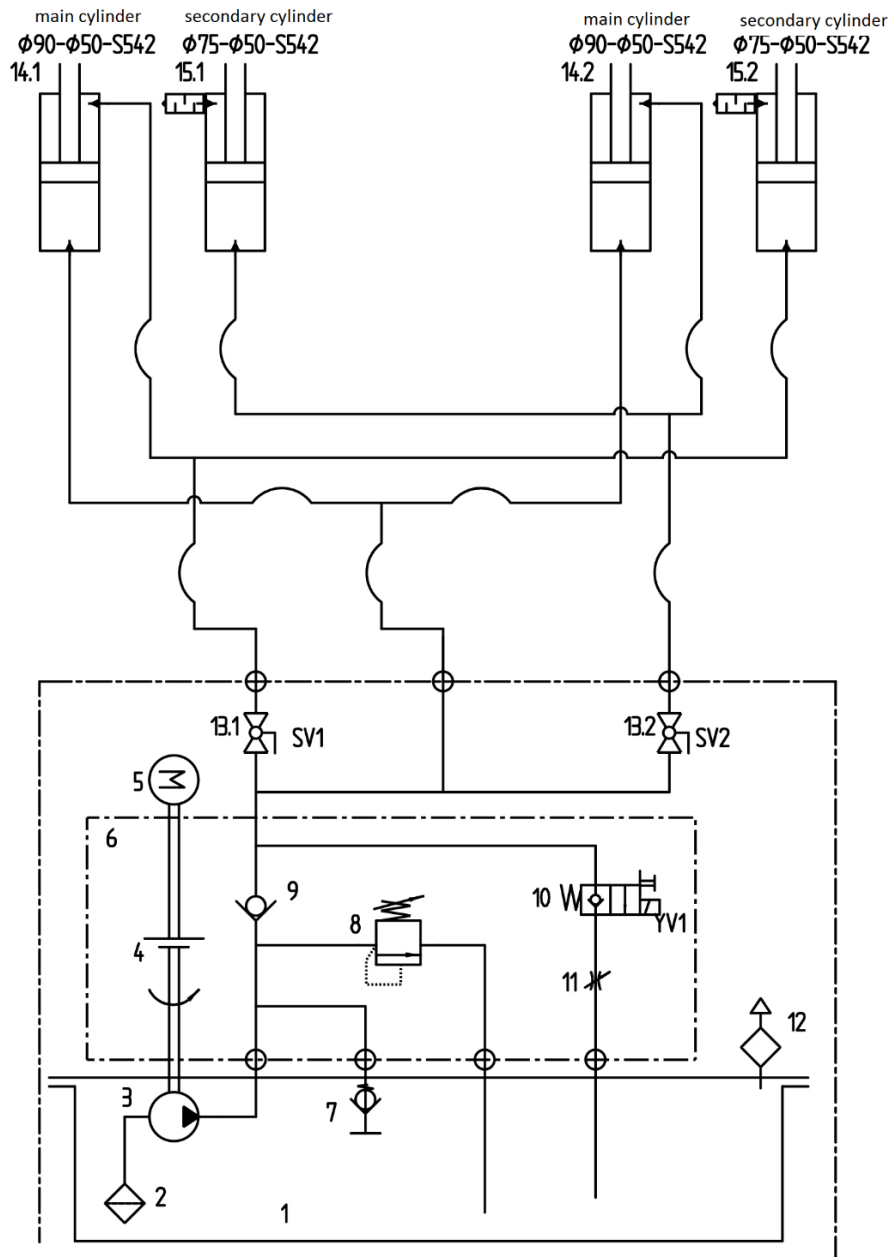
Annex 2, Hydraulic schemes and parts list

Seal Rings

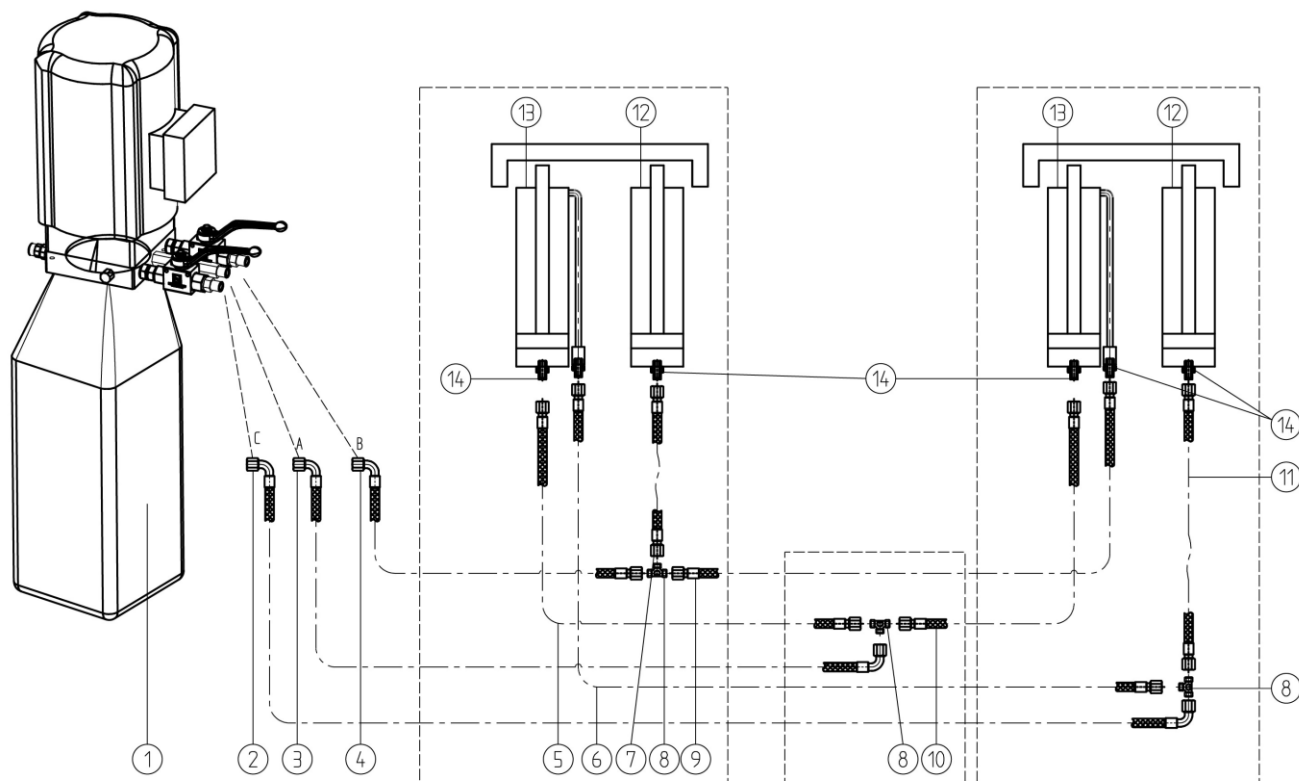
Cylinder Code	Seal ring code	Seal ring	Specification	Qty
615019601 (65A-MCYL)	207103031	Type Y seal ring	B7-90*75*9	2
	207103022	Type Y seal ring	BS 50*60*6	2
	207105007	Dust proof ring	DHS50 (50*58*6)	1
615019602 (65A-SCYL)	207103032	Type Y seal ring	B7-75*60*9	1
	207105007	Dust proof ring	DHS50 (50*58*6)	1

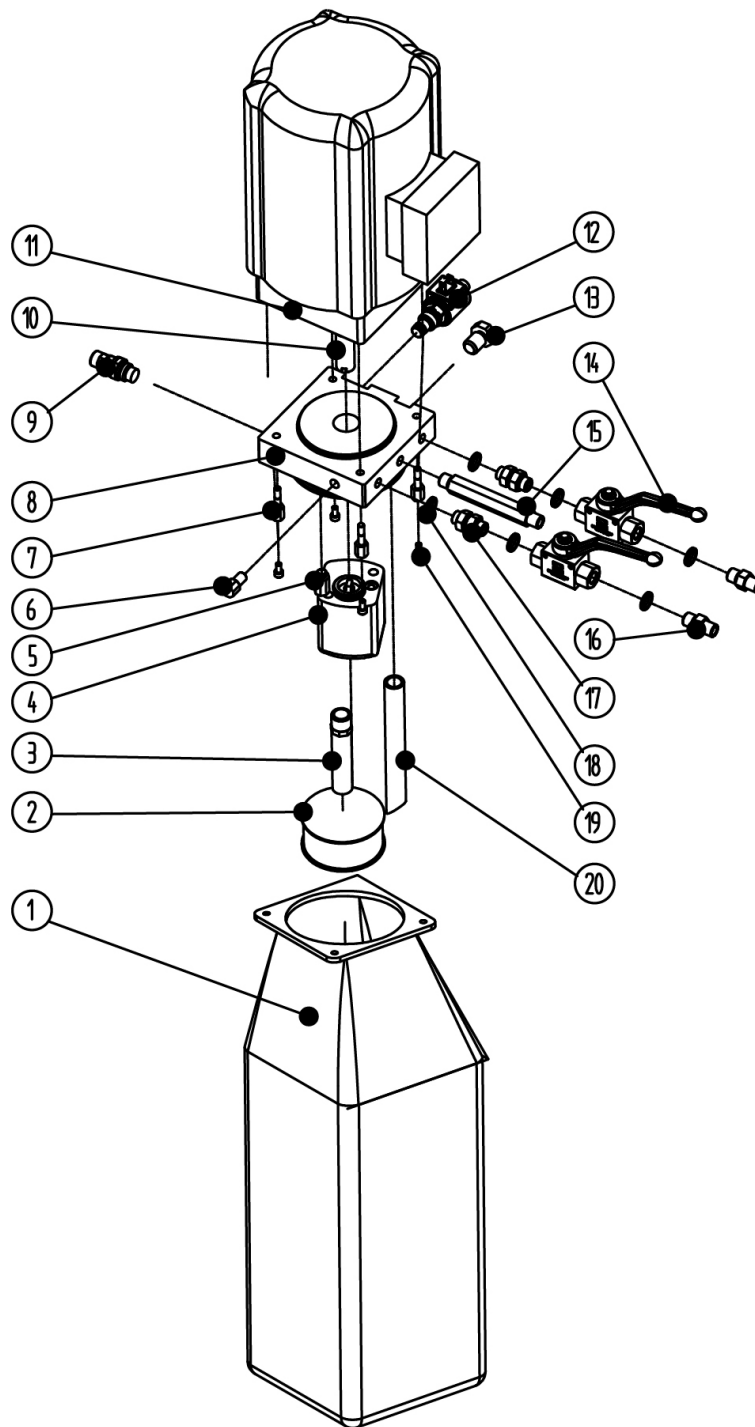

POS.	CODE	Description	Specification	Qty
1		Power unit	2.2kW	1
2	624001899	Rubber oil hose	L=5500	1
3	624001900	Rubber oil hose	L=4850	1
4	624001004	Rubber oil hose	L=4100	1
5	624001898	Rubber oil hose	L=900	1
6	624001062	Rubber oil hose	L=1650	1
7	624001130	Rubber oil hose	L=200	1
8	410210181	Three way connector	6603B-A9-B7	1
9	624001062	Rubber oil hose	L=1650	1
10	624001898	Rubber oil hose	L=900	1
11	624001005	Rubber oil hose	L=230	1
12	615019602	Secondary cylinder	YG5090-542	2
13	615019601	Main oil cylinder	YG5075-542	2
14	310101028	Shifting connector	G1/4,M14x1.5,M14x1.5,	6



Pos.	CODE	Description	Specification	Qty
1	330405001	Oil tank	10L	1
2	330403001	Oil sucking filter	YG-C	1
3	330401005	Oil sucking tube	YX-BL-293	1
4	330201005	Gear pump assembly (for 2.2kW,3Ph motor)	CBK-F220/CBK-2.1F	1
4	330201004	Gear pump assembly (for 2.2kW,1Ph motor)	CBK-F216	1

Pos.	CODE	Description	Specification	Qty
4	330201007	Gear pump assembly (for 3.0kW,3Ph motor)	CBK-F233	1
5	330301001	Cushion valve	HZYF-C1	1
6	330305002	Throttle valve	-	1
7	202109064	Hex socket cylinder head screw	M6*30	4
8	330101007	Hydraulic block	YF-4	1
9	330304001	Over flow valve	EYF-C	1
10	330404001	Coupling	YL-A	1
11	320201001	Motor	220V-2.2KW -1PH-50HZ-2p	1
	320201002	Motor	230V-2.2KW -1PH-50HZ-2P	1
	320201003	Motor	240V-2.2KW -1PH-50HZ-2P	1
	320201004	Motor	380V-2.2KW -3PH-50HZ-2p	1
	320201005	Motor	400V-2.2KW -3PH-50HZ-2P	1
	320201006	Motor	415V-2.2KW -3PH-50HZ-2P	1
	320204016	Motor	380V-3.0KW-3PH-50HZ-2P	1
	320204017	Motor	400V-3.0KW-3PH-50HZ-2P	1
	320204018	Motor	415V-3.0KW -3PH-50HZ-2P	1
12	330308006	Solenoid unloading valve	DHF06-220H/DC24	1
13	330302001	Single way valve	DYF-C	1
14	330307001	Two way ball valve	GE2G1/4111AB	2
15	310101026	Straight connector	G1/4-G1/4 L=120	1
16	310101010	Straight connector	G1/4-G1/4	2
17	615019005	Tube connector B	G1/4-G1/4	2
18	207103019	Composite washer	M14	6
19	201102002	Hex head full swivel screw	M5*10	4
20	330402001	Oil back tube	YH-D	1

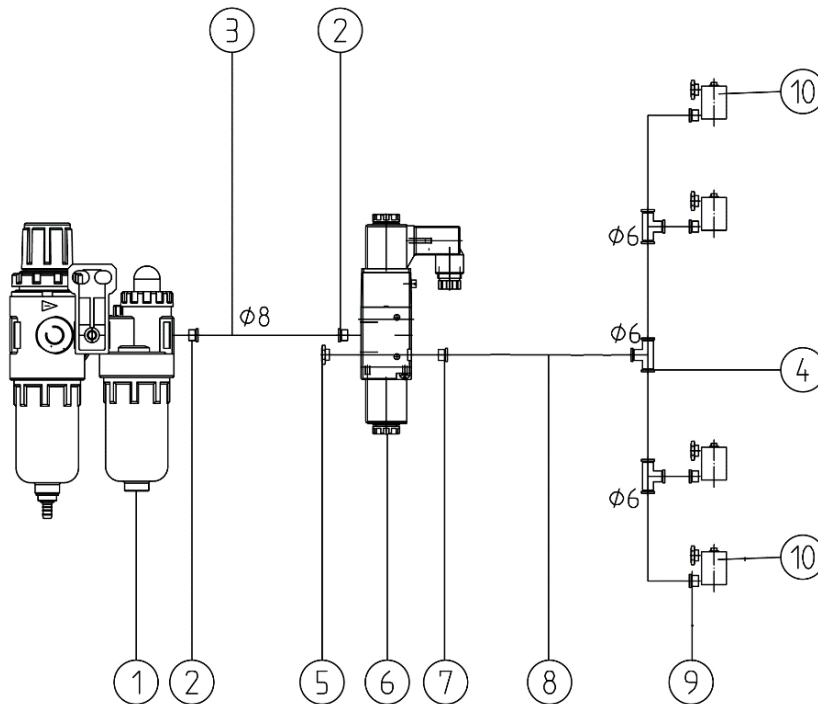
Annex 3, Pneumatic schemes and parts list

POS.	CODE	Description	Specification	Qty
1	321004006	AFC Air filter combination	AFC2000-M	1
2	310101015	Pneumatic connector	KLC8-02	3
3	123010201	Air hose	D=8	1
4	310103005	Three way connector	KLE-6	3
5	310201002	Silencer	SLM02 R1/4 (M12)	1
6	310401001	Pneumatic solenoid valve	3V210-08DC24V	1
7	310101014	Straight pneumatic connector	KN6-02	1
8	123010101	Pneumatic hose	D=6	1
9	310101018	Quick straight pneumatic connector	KLC6-M5	4
10	310501020	Pneumatic cylinder	SDA20*25	4

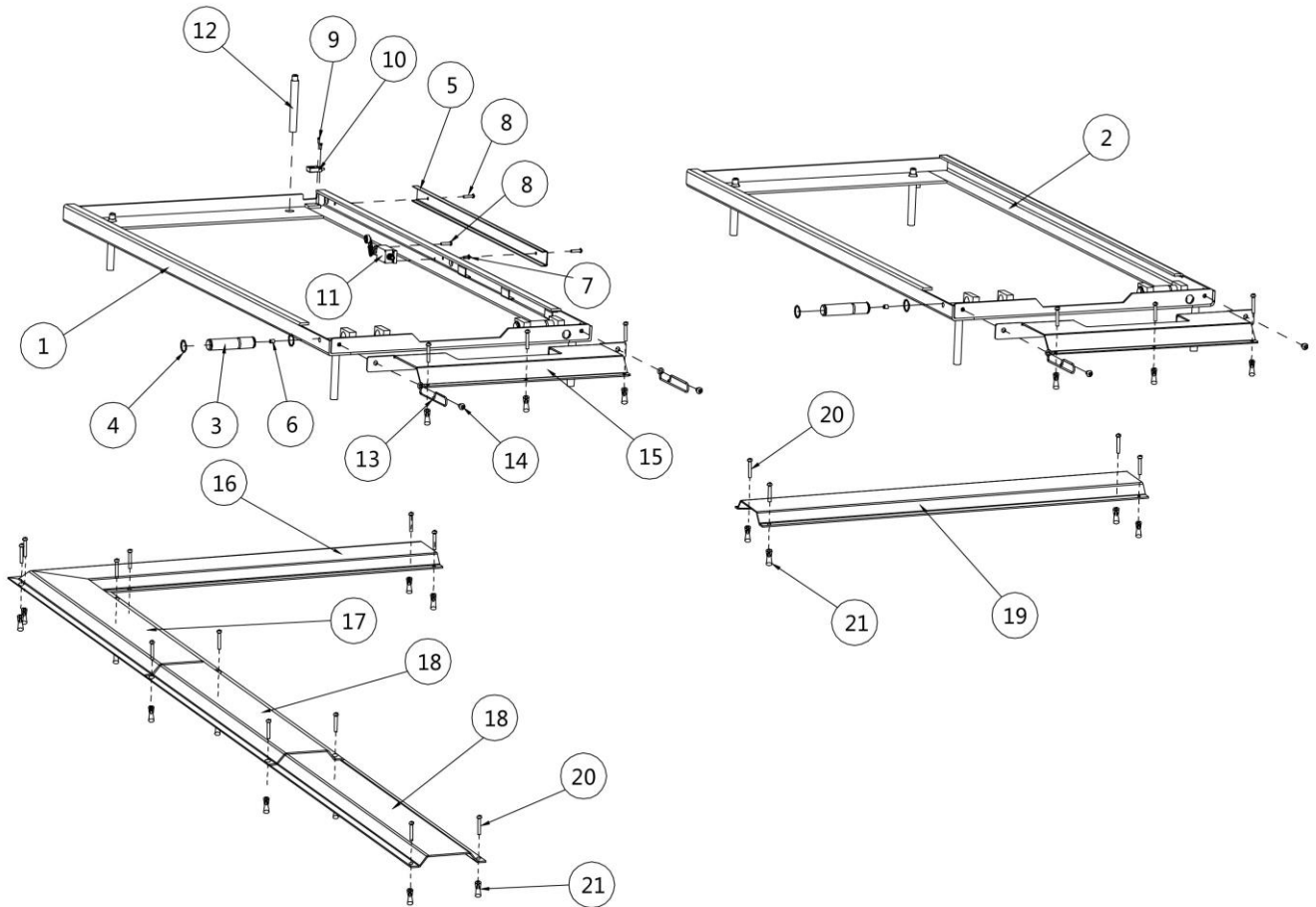
Annex 4, Mechanically exploded drawings and parts list

Pos.	CODE	Description	Specification	Qty
1	614065001	Base plate A	65A40-A1-B1	1
2	614065002	Base plate B	65A40-A1-B2	1
3	410197281	Roll shaft of base plate	65A40-A1-B3	4
4	204301009	Circlip	M25	8
5	410650203	Hose protective slot	65A40-A1-B4	1
6	208106002	Pressed oil cup	M8	4
7	202101022	Cross socket cap head screw	M5*12	1
8	202101023	Cross socket cap head screw	M5*16	3
9	202101040	Cross socket cap head screw	M3*10	2
10	320306010	Proximity sensor	Y18-Z-PK4	1
11	320301009	Max height limit switch	TZ-8104	1
12	201201005	Expansion bolt	M16*120	8
13	410650031	Oil hose fixer	65A40-A1-B5	3
14	202110004	Hex socket button head screw	M8*12	4
15	410650193	Protective cover D	65A40-A7	2

Pos.	CODE	Description	Specification	Qty
16	410190043	Protective cover C	6501-A11	1
17	410190033	Protective cover B	6501-A10	1
18	410190023	Protective cover A	6501-A9	2
19	410650763	Protective cover E	65A40-A8	1
20	202301008	Cross socket cap head tapping screw	ST4.8*35	22
21	121010103	Plastic expansion tube	M10*40	22

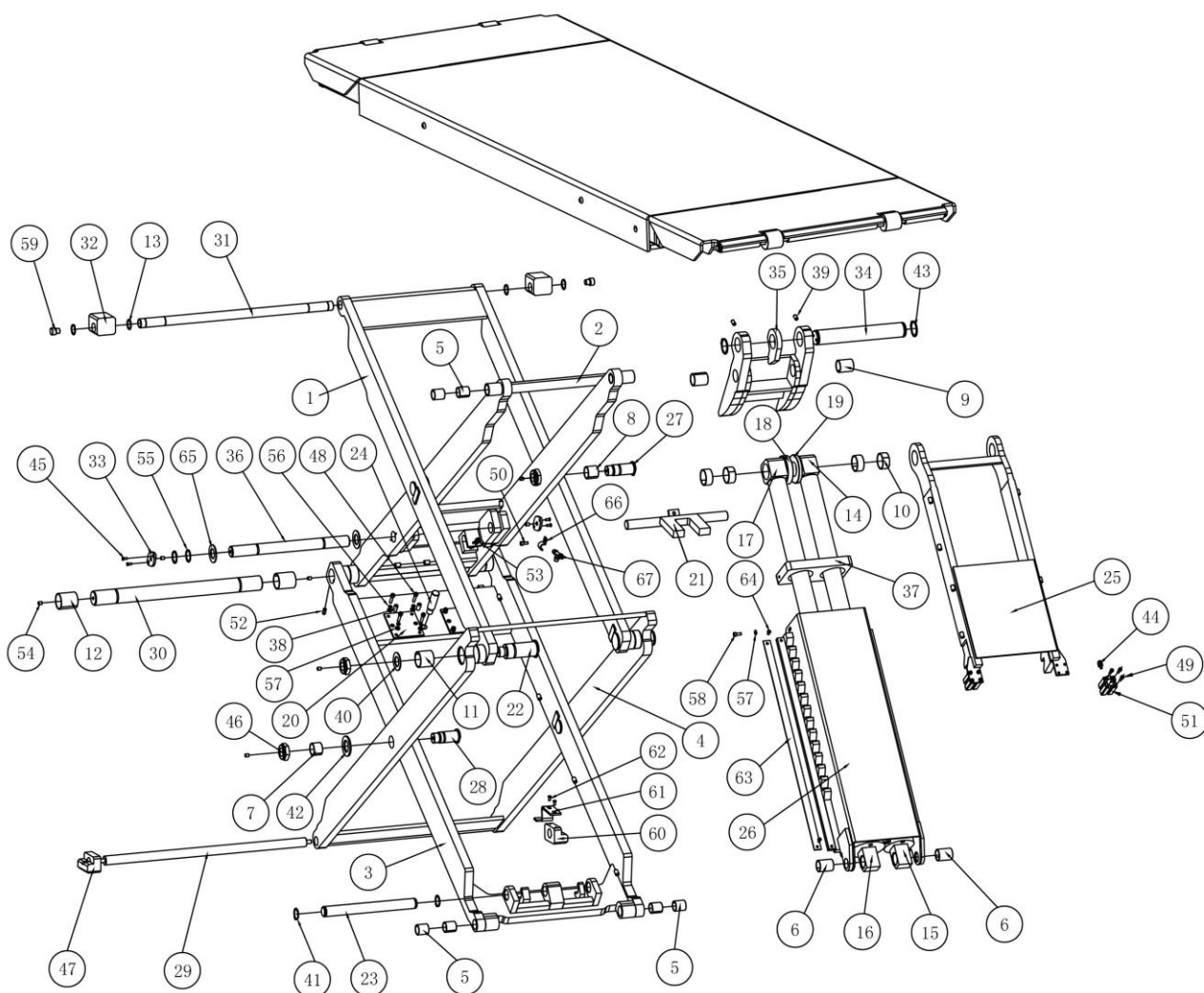

Pos.	CODE	Description	Specification	Qty
1	614065004	Support scissor bracket A	65A40-A2-B1	2
2	614065005B	Support scissor bracket B	65A40-A2-B2	2
3	614065006	Support scissor bracket C	65A40-A2-B3	2
4	614065007	Support scissor bracket D	65A40-A2-B4	2
5	205101012	Bearing	2530_SF-1X	16
6	205101053	Bearing	2840_SF-2X	4
7	205101018	Bearing	3025_SF-1X	4

Pos.	CODE	Description	Specification	Qty
8	205101020	Bearing	3030_SF-1X	4
9	205101021	Bearing	3040_SF-1X	4
10	205101037	Bearing	4020_SF-1	8
11	205101035	Bearing	4040_SF-2X	4
12	205101036	Bearing	4050_SF-1X	4
13	204301009	Circlip	M25	8
14	410190151	Oil cylinder connector B	6501-A4-B1	2
15	615019602	Secondary oil cylinder	65A40-A4-B7	2
16	615019601	Main oil cylinder	65A40-A4-B8	2
17	410190141B	Oil cylinder connector A	6501-A4-B11	2
18	410650801	Wheel A for cylinder shaft	65A40-A4-B10	2
19	410197370B	Wheel B for cylinder shaft	65A40-A4-B4	2
20	410197391B	Start padding plate	65A40-A2-B18	4
21	614065015	Flat plate	65A40-A6-B1	2
22	410197051	Pin shaft B of the arm	65A40-A2-B7	4
23	410197081	Downside shaft of oil cylinder	65A40-A2-B12	2
24	410197321	Support rod	65A40-A2-B15	2
25	614065009B	Safety locking teeth	65A40-A4-B1	2
26	614065010	Sheath of the safety lock	65A40-A4-B2	2
27	410197031	Pin shaft D of the arm	65A40-A2-B6	4
28	410197061	Pin shaft A of the arm	65A40-A2-B10	4
29	410197291	Shaft of the downside slider	65A40-A2-B11	2
30	410197041	Pin shaft C of the arm	65A40-A2-B9	2
31	410197020	Upside slider shaft	65A40-A2-B5	2
32	420197010	Upside slider	65A40-A2-B8	4
33	410197311	Block for start plate	65A40-A2-B14	4
34	410197201C	Upside shaft of oil cylinder	65A40-A3-B2	2
35	614065008B	Start plate	65A40-A3-B1	2
36	410197131B	Shaft of the start plate	65A40-A2-B13	2
37	410197261	Oil cylinder flange	65A40-A4-B3	2
38	206104001	Post pin (inside swivel)	10*22	8
39	202207002	Hex socket set screw	M8*16	4
40	204101014	Flat washer	D27	12
41	204301010	Circlip	M28	4
42	204101015	Flat washer	M30	4
43	204301014	Circlip	M40	4
44	310101018	Quick straight pneumatic connector	KLC6-M5	4
45	202101007	Hex socket flat head screw	M8*20	8
46	203103016	Hex locking nut	M27	12
47	420194020	Downside slider	65A40-A2-B16	3
48	202109021	Hex socket cylinder head screw	M6*20	16

Pos.	CODE	Description	Specification	Qty
49	202109009	Hex socket cylinder head screw	M5*15	16
50	202109007	Hex socket cylinder head screw	M5*8	4
51	310501020	Pneumatic cylinder	20*32	4
52	202206003	Hex socket tighten screw	M8*20	4
53	202109033	Hex socket cylinder head screw	M8*40	4
54	208106002	Pressed oil cup	M8	20
55	204301011	Circlip	M30	4
56	204201003	Spring washer	M6	16
57	204101004	Flat washer	M6	20
58	202109020	Hex socket cylinder head screw	M6*15	4
59	420210060B	Padding block	6603B-A5-B6	4
60	420650020	Limitation slider	65A40-A2-B19	1
61	410650041	Downside plate for limit switch	65A40-A2-B17	1
62	202101008	Cross socket cap head screw	M4*10	2
63	410650021	Sliding plate for pneumatic cylinder	65A40-A4-B9	4
64	202101021	Cross socket cap head screw	M5*10	8
65	410200181	Washer for support bracket	6503-A5-B7	4
66	410060021	Oil hose fixer	6254-A1-B4(6214A-A1-B4)	4
67	310103005	Quick three way pneumatic connector	KLE-6	3

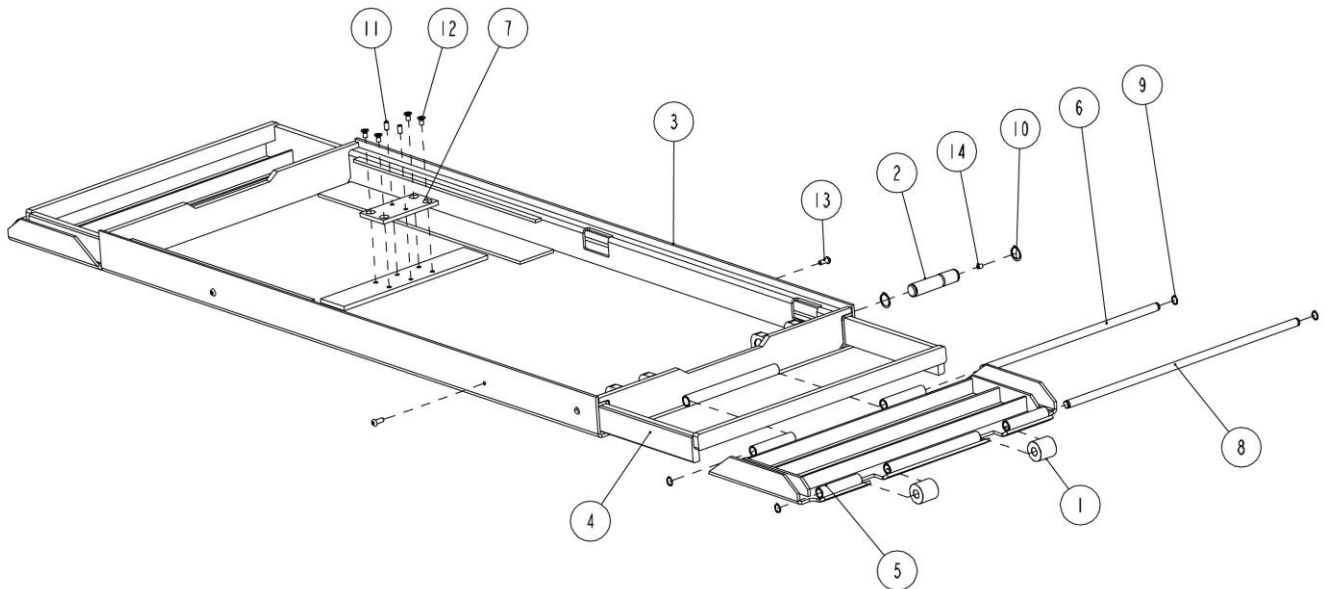

Pos.	CODE	Description	Specification	Qty
1	420270250	Roll wheel	6435BWF-C08-9	4
2	410197281	Roll shaft of base plate	65A40-A1-B3	2
3	614065018	Platform assembly	65A40-A5-B1	1
4	614065020	Extendable bracket	65A40-A5-B2	2
5	614065019	Ramp	65A40-A5-B3	2

Pos.	CODE	Description	Specification	Qty
6	410650951	Shaft of the ramp	65A40-A5-B4	2
7	410197301	Platform installation plate	65A40-A5-B5	1
8	410650941	Shaft of the wheel	65A40-A5-B6	2
9	204301004	Circlip	D15_GB894_1-86	8
10	204301009	Circlip	D25_GB894_1-86	4
11	206101010	Inside swivel post pin	D8X16-GB120	2
12	202103019	Cross socket flat head screw	M8X10-GB819	4
13	202110005	Hex socket button head screw	M8X20_GB70_2	4
14	208106002	Pressed oil cup	M8YP_GB7940_4	2